



INfac011\_US\_CA

**370-130V80**



## CHILDREN'S ELECTRONIC TOY QUAD

1. Suitable age for 18-36 Months.
2. Maximum user weight: 20KGS.
3. Adult assembly required

### OWNER'S MANUAL

with Assembly Instructions

Read and understand this entire manual before using!

Please keep this manual for future reference as it contains important information.

Before first time use, charge the battery for at least 8-12 hours.

# ASSEMBLY INSTRUCTION

# About Your New Vehicle

## Specification

Item	Specifications
Battery	6V4.5AH
Motor	380#
Maximum weight	20KGS
Size	78.5X40.5X46CM
Speed	3Km/h
Using time	working for 1-2 hours, once charged for 8-12 hours
Available ages	Children at 18-36 months
Charger	DC6V500mA





## Disposal Of Battery

1. Your sealed lead-acid battery must be recycled or disposed of in an environmentally sound manner.
2. Do not dispose of your lead-acid battery in a fire. The battery may explode or leak
3. Do not dispose of a lead-acid battery in your regular, household trash. The incineration, land filling or mixing of sealed lead-acid batteries with household trash is prohibited by law.

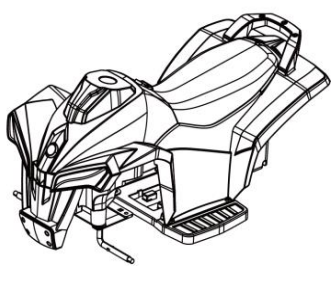
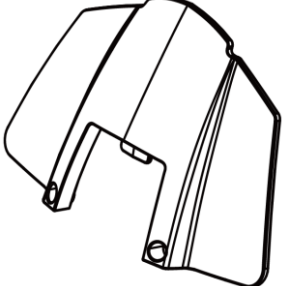
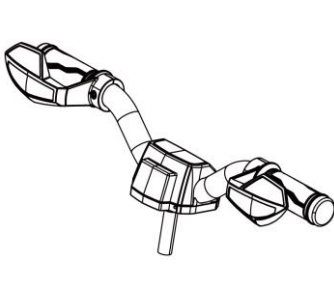
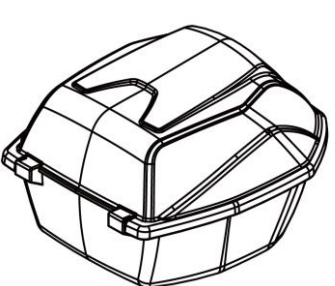
Our products are suitable for ASTM F963; CPSIA; EN71 and EN62115 standard.

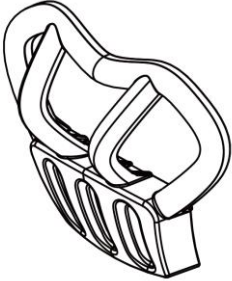

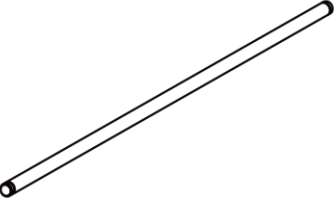
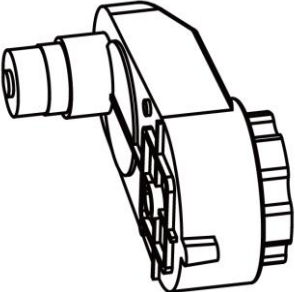
## Parts Diagram

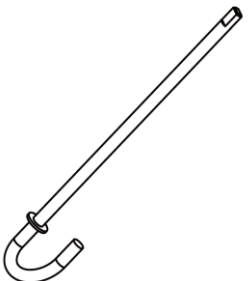
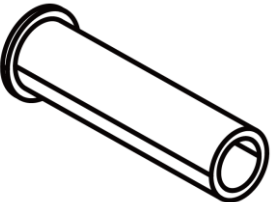
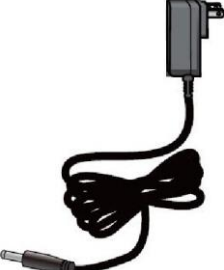
			
1.body	2. Windshield	3.handlerbar	4.Trunk

			
<b>5.Bumper</b>	<b>6.front wheel X3</b>	<b>7.A rear axle</b>	<b>8.motor</b>
			
<b>9.rear wheel X1</b>	<b>10.Steering shaft</b>	<b>11.Axle sleeve</b>	<b>12.charger</b>

**Windshield and motor in battery compartment**

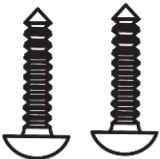
**Number of screw packs**

<b>1</b> 	<b>2</b> 	<b>3</b> 	<b>4</b> 
<b>1.10MM GASKET X8</b>	<b>2.4X10 SCREW X10</b>	<b>3.M8 CHECK BACK NUT X4</b>	<b>4.M10 CHECK BACK NUT X1</b>

**Attach the Side Wheels & Rear Fender**

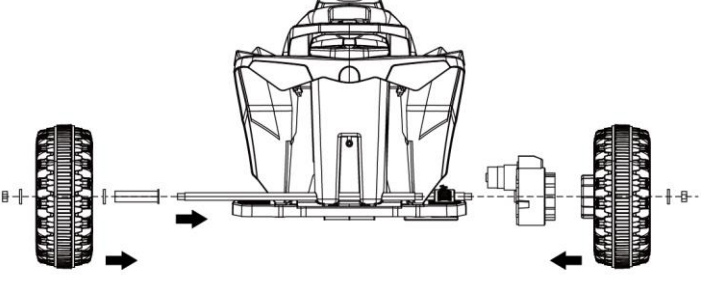
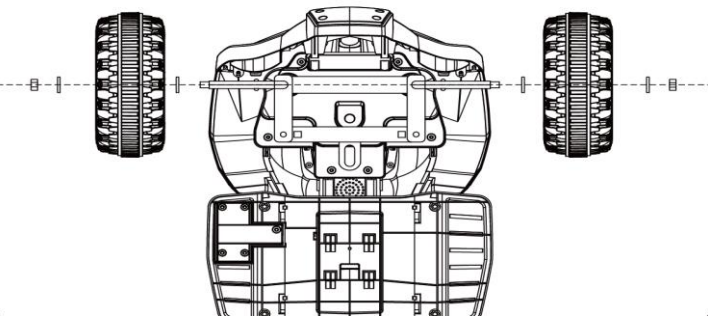
	
<b>1. insert the back axis, assemble the gear motor &amp; Axle sleeve, assemble back wheels, fix the wheels(2XM8 NUT&amp;3X10MM GASKET)</b>	<b>2.fix the front wheel(2XM8 NUT&amp;4X10MM GASKET)</b>

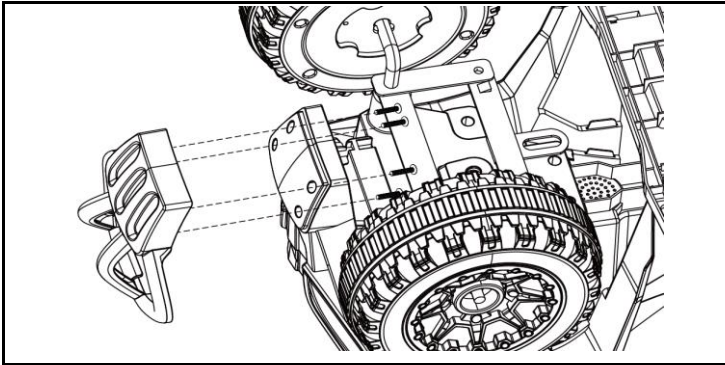

**3.Install bumper(4X(4X10)SCREW)**

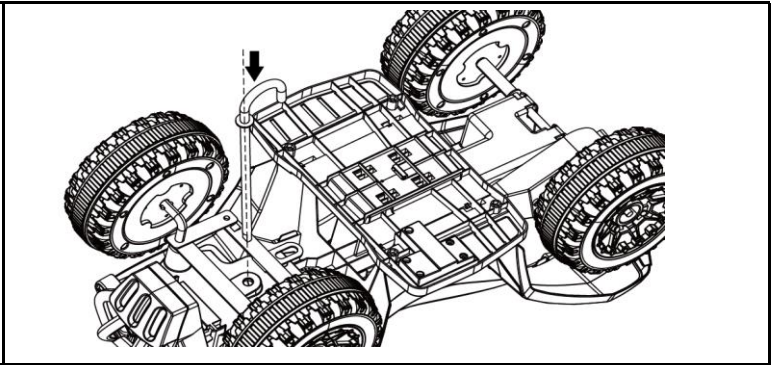

**4.Flip the car bottom up,then insert steering shaft**

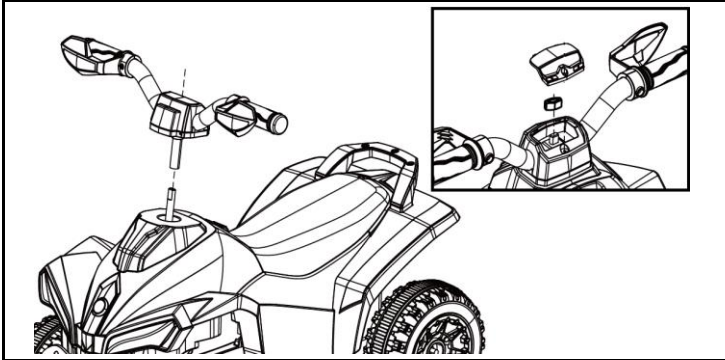

**5.Insert handlerbar into the axial shaft ,secure with(1XM10 NUT)**

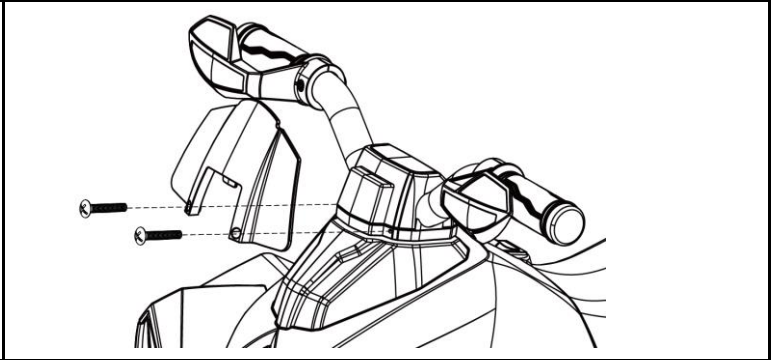

**6.Fasten the windshield to the handlebar,(2X(4X10)SCREW)**

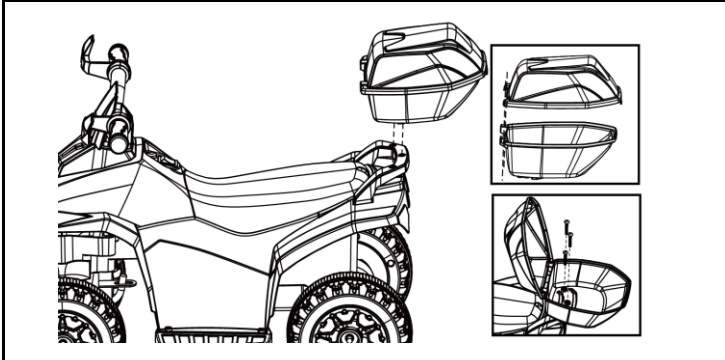

**7.Fix the trunk (3X(4X10)SCREW)**

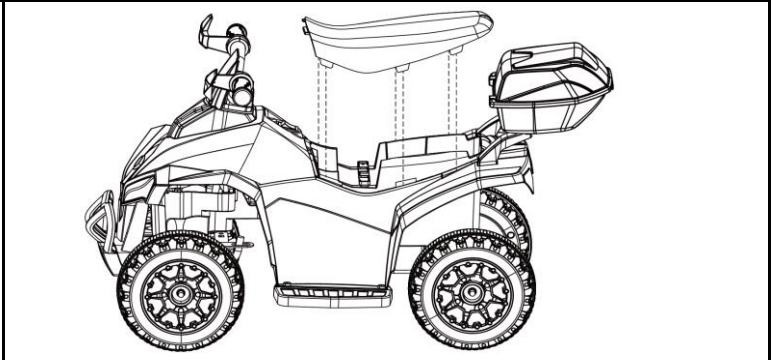

**8.OPEN THE SEAT**

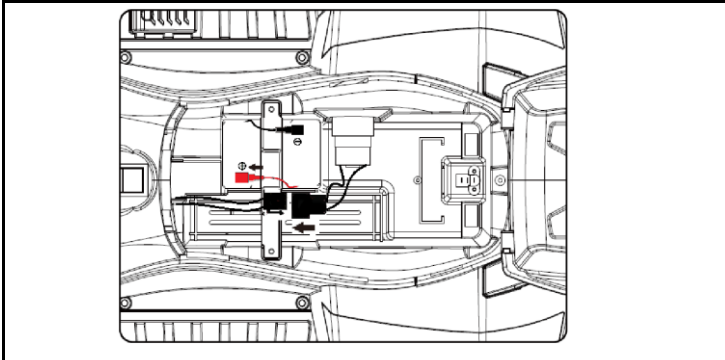

**9.CONNECT THE MOTOR ELECTRIC LINE INTO THE MOTOR**

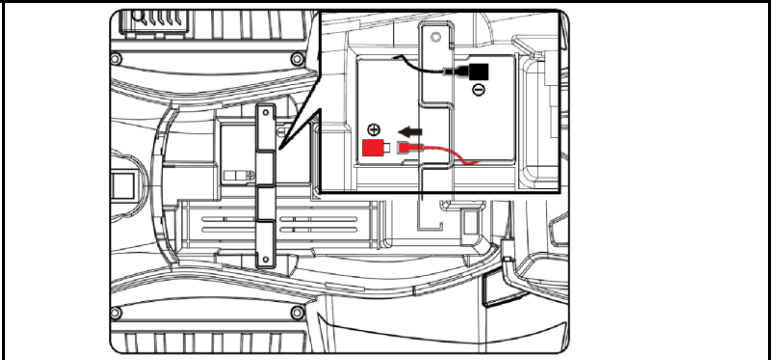

**10.CONNECT THE BATTERY ELECTRIC LINE INTO THE BATTERY**

