

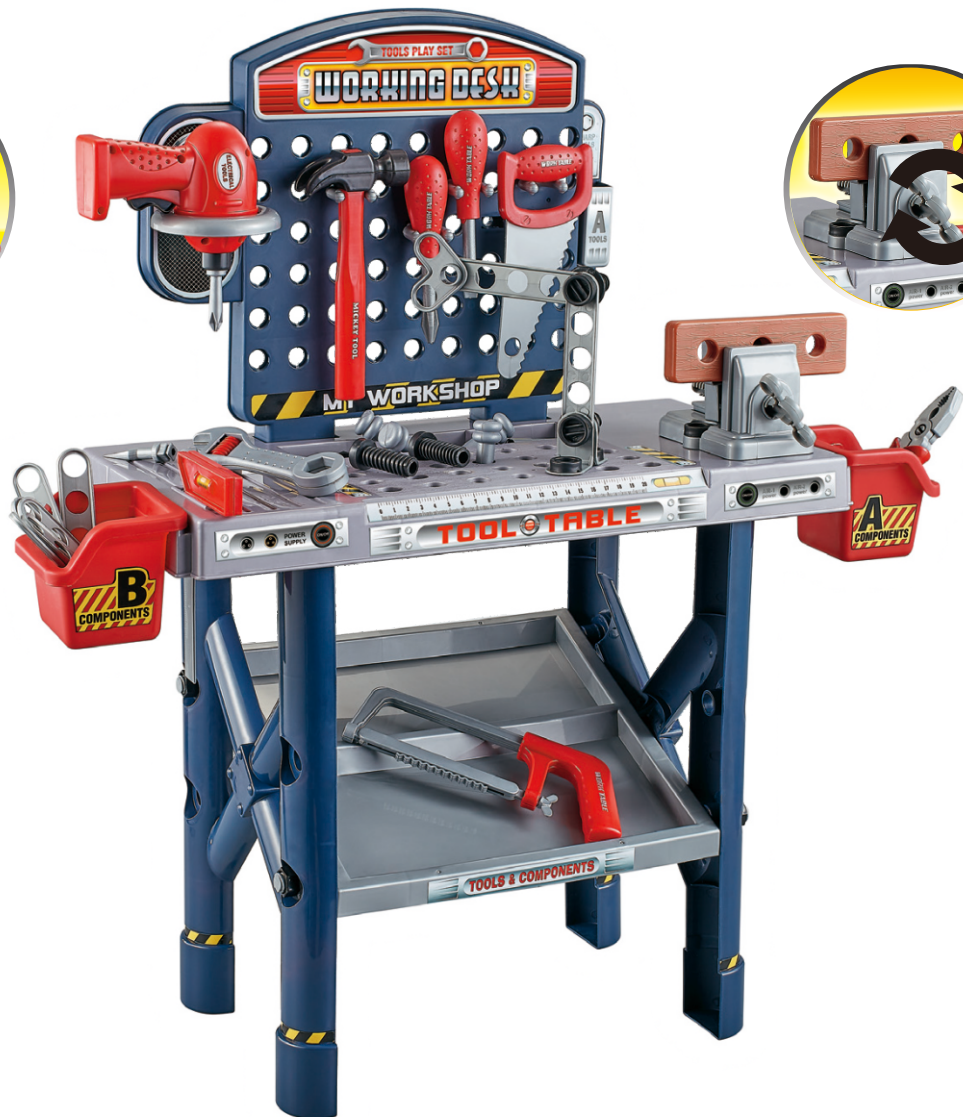

INfbb011_US_CA

350-111



*Suitable for children of 3-6 years old;

*Convient aux enfants de 3 à 6 ans;



IMPORTANT, RETAIN FOR FUTURE REFERENCE: READ CAREFULLY

ASSEMBLY INSTRUCTION

WARNING:

1. CHOKING HAZARD—Small parts. Not for children under 3 years.
2. Only allowed for adults to install, keep children away.
3. To be used under the direct supervision of an adult.
4. Keep away from fire! Keep away from water!

MAINTENANCE & CARE

- A. Keep all instructions and parts relating to this product for future reference.
- B. If any problem occurred, please sent it to qualified maintainer.
- C. Clean your toy with a clean damp cloth.

BATTERY WARNING:

1. Do not mix alkaline, standard or rechargeable batteries.
 2. Never mix old and new batteries.
 3. Batteries are to be inserted with the correct polarity.
 4. Remove the batteries when the unit is not in use for long periods.
 5. Always comply with local laws and regulations.
-

AVERTISSEMENT :

1. RISQUE D'ÉTOUFFEMENT - Petites pièces. Déconseillé aux enfants de moins de 3 ans.
2. Installation par des adultes uniquement, tenir les enfants à l'écart.
3. À utiliser sous la surveillance directe d'un adulte.
4. Loin du feu ! Loin de l'eau !

ENTRETIEN ET MAINTENANCE

- A. Conservez toutes les instructions et les pièces relatives à ce produit pour pouvoir vous y référer ultérieurement.
- B. Si un problème survient, veuillez l'envoyer à un technicien qualifié.
- C. Nettoyez votre jouet avec un chiffon propre et humide.

AVIS RELATIF AUX PILES :

1. Ne pas mélanger les piles alcalines, standard ou rechargeables.
2. Ne mélangez jamais des piles anciennes avec de nouvelles piles.
3. Les piles doivent être insérées avec la bonne polarité.
4. Retirez les piles lorsque l'appareil n'est pas utilisé pendant une longue période.
5. Respectez toujours les lois et règlements locaux.

① x 1



② x 1

③ x15
(+1 spare)

④ x 8



⑤ x10



⑥ x 1



⑦ x 1



⑧ x 1



⑨ x 1



⑩ x 1



⑪ x 1



⑫ x 1



⑬ x 1



⑭ x 4



⑮ x 2



⑯ x 1



⑰ x 1



⑱ x 1



19 x 4



20 x 1



21 x 1



22 x 1



23 x 1



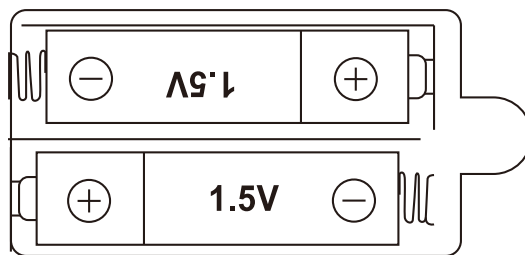
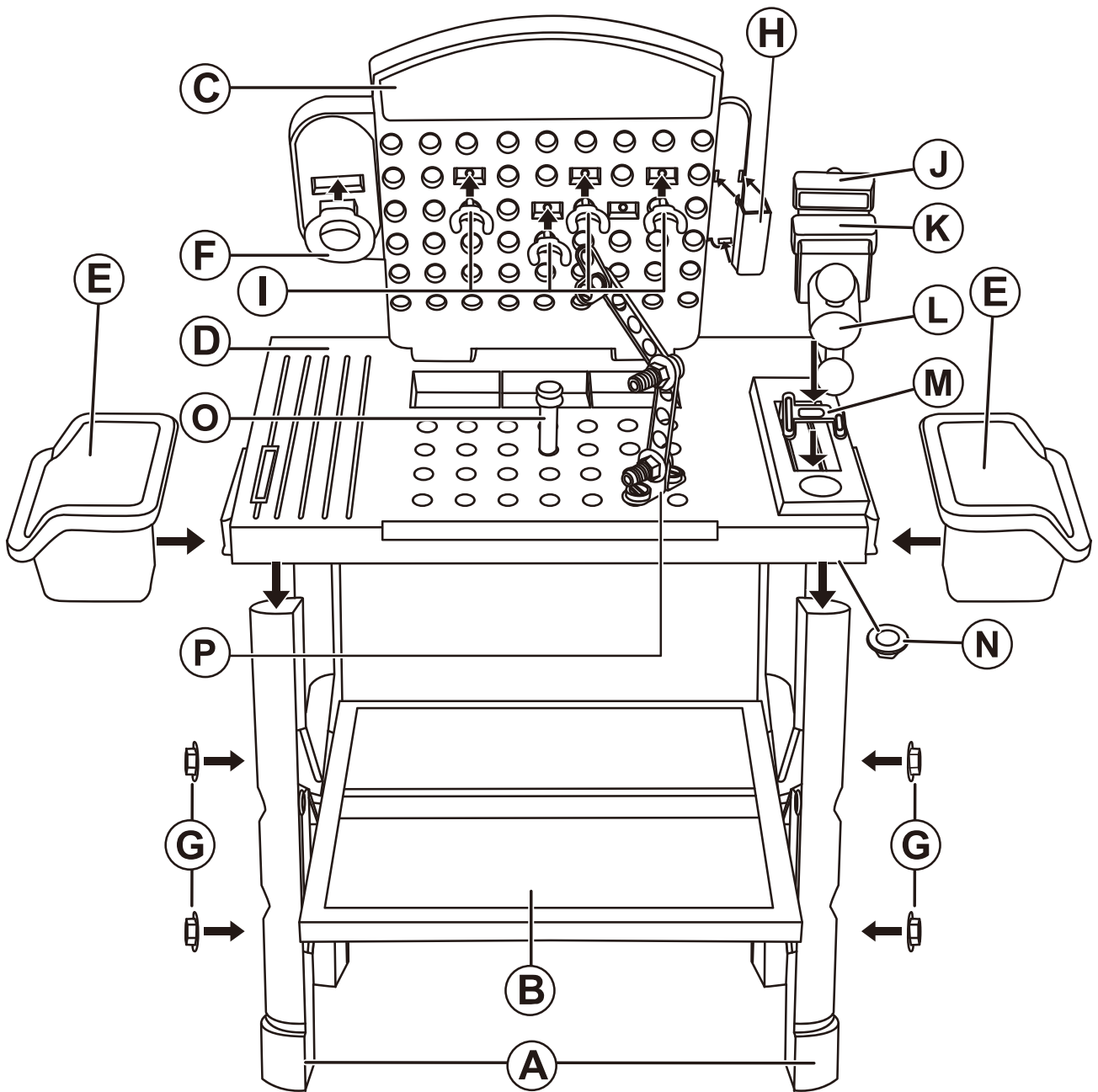

USE 2X1.5V "AAA" BATTERIES
(NOT INCLUDED)

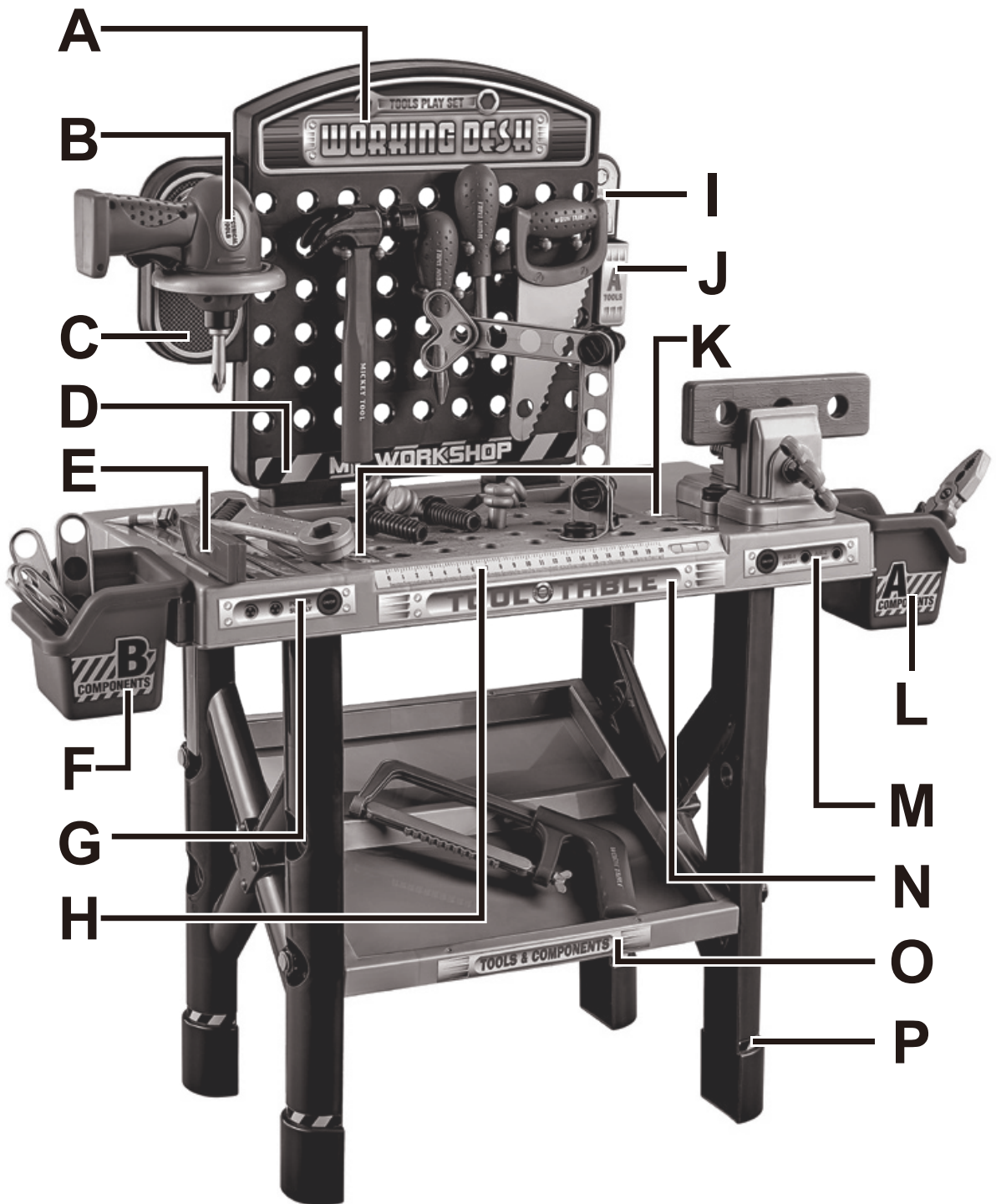
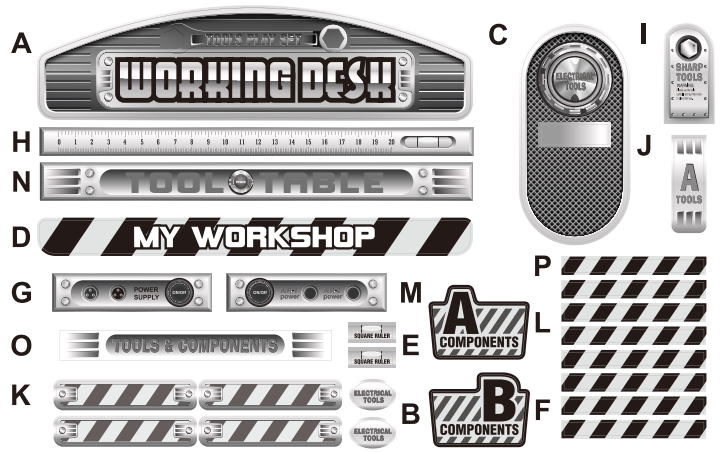

US



001-877-644-9366
customerservice@aosom.com

CA



001-855-537-6088
customerservice@aosom.ca

UK



0044-800-240-4004
enquiries@mhstar.co.uk

DE



0049-(0)40-88307530
service@aosom.de

FR



0033-1-84166106
contact@aosom.fr

ES



0034-931294512
atencioncliente@aosom.es

IT



0039-0249471447
clienti@aosom.it