

**Safety:**the product should be assembled by adult,not suitable for children under three years.

**Sicherheit:**dieses produkt sollte von erwachsenen, nicht geeignet für kinder unter drei jahren zusammengebaut werden.

**Sécurité :**ce produit doit etre monté par un adulte, ne convient pas aux enfants de moins de 3 ans.

**Seguridad:**el producto debe ser montado por un adulto responsable. No apto para niños menores de 3 años de edad.



**Sicurezza:**il prodotto deve essere assemblato da un adulto, non è adatto a bambini di età inferiore ai 3 anni.

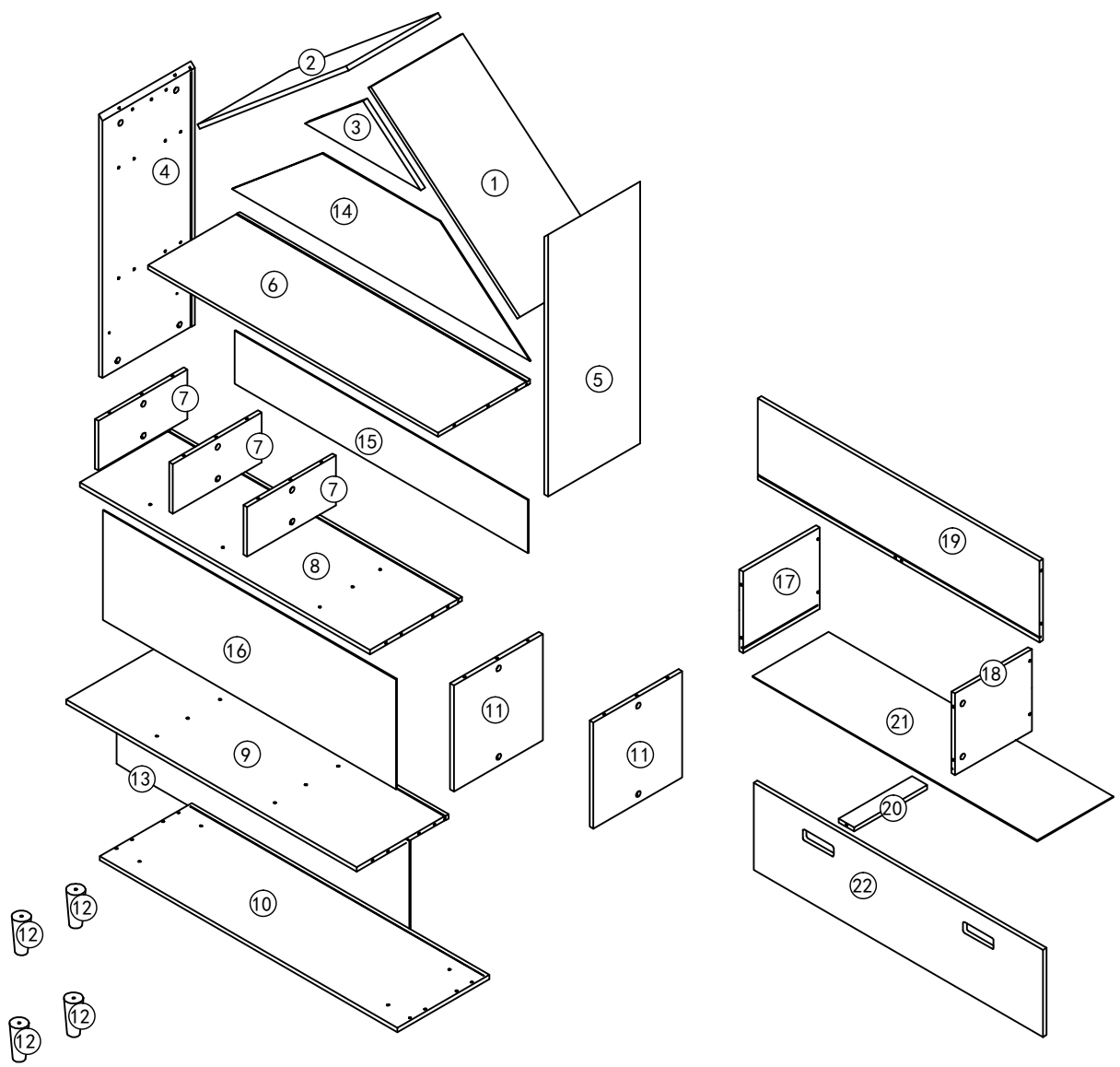
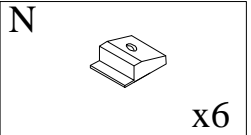
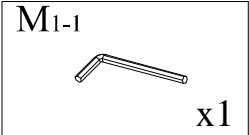
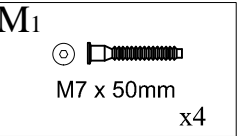
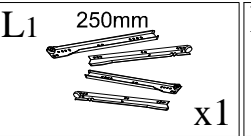
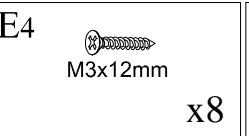
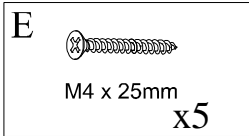
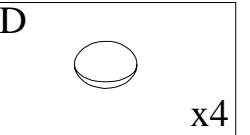
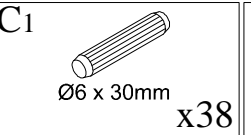
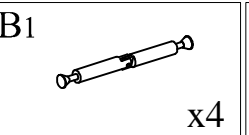
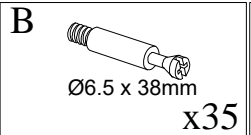
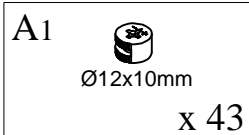

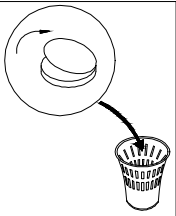
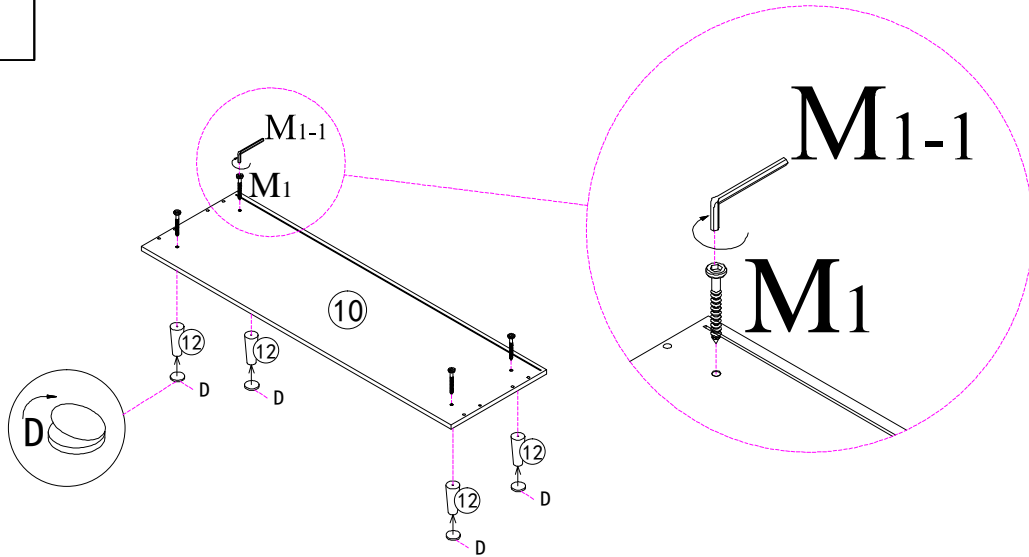

1



|   |   |   |
|---|---|---|
| <p>D</p>  <p>x4</p> | <p>M1-1</p>  <p>x1</p> | <p>M1</p>  <p>M7 x 50mm</p> <p>x4</p> |
|---|---|---|

2

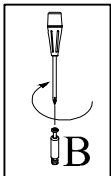
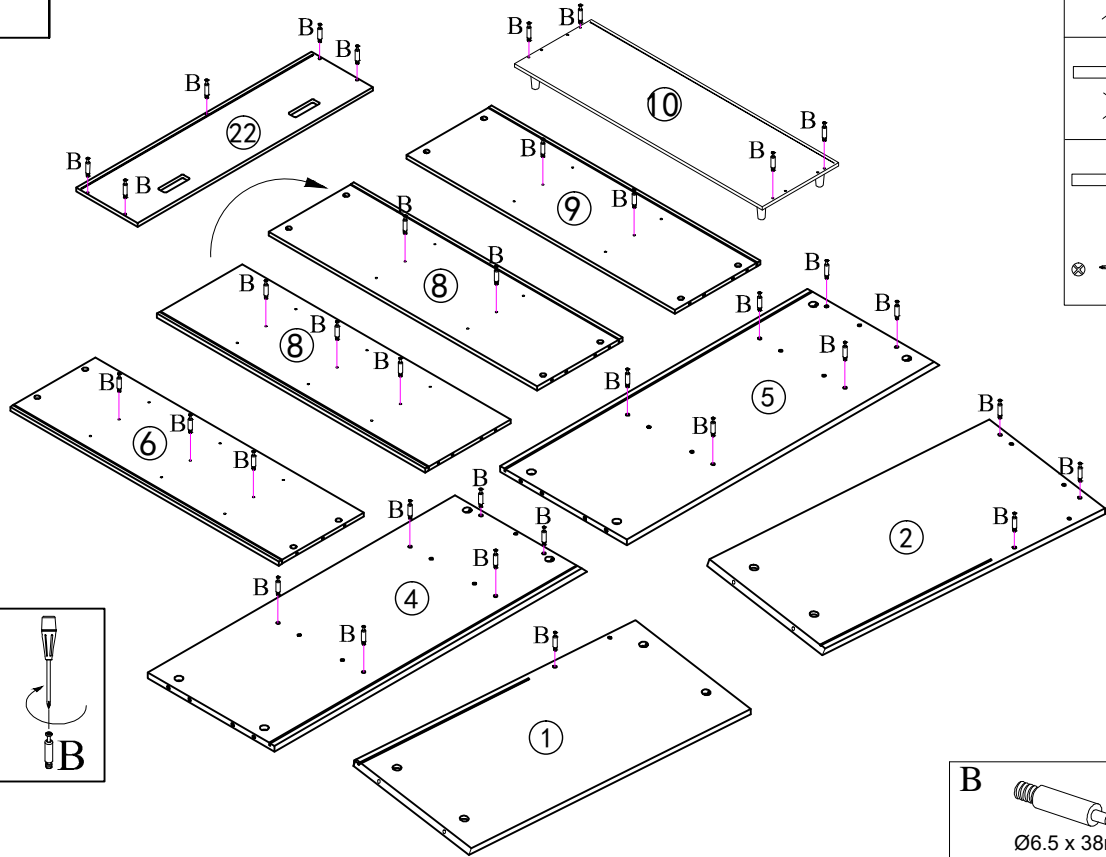

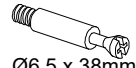
|  |
|--|
| <p>B</p>  <p>Ø6.5 x 38mm</p> <p>x35</p> |
|--|

3

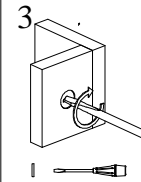
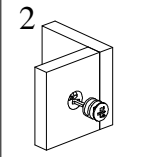
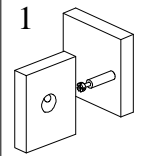
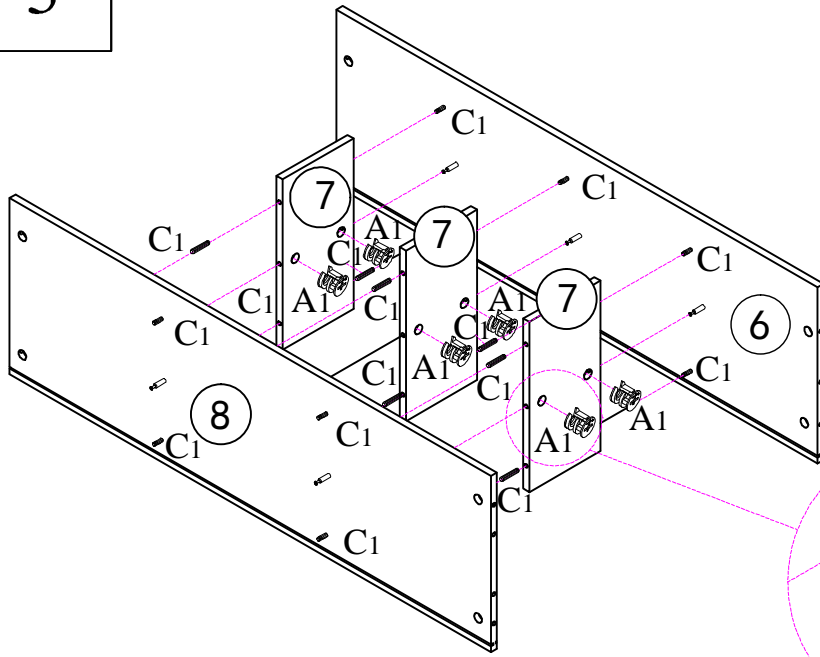

A1   
 Ø12x10mm  
 x 6

C1   
 Ø6 x 30mm  
 x16

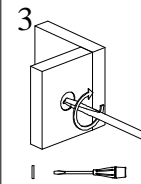
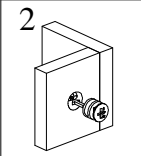
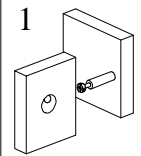
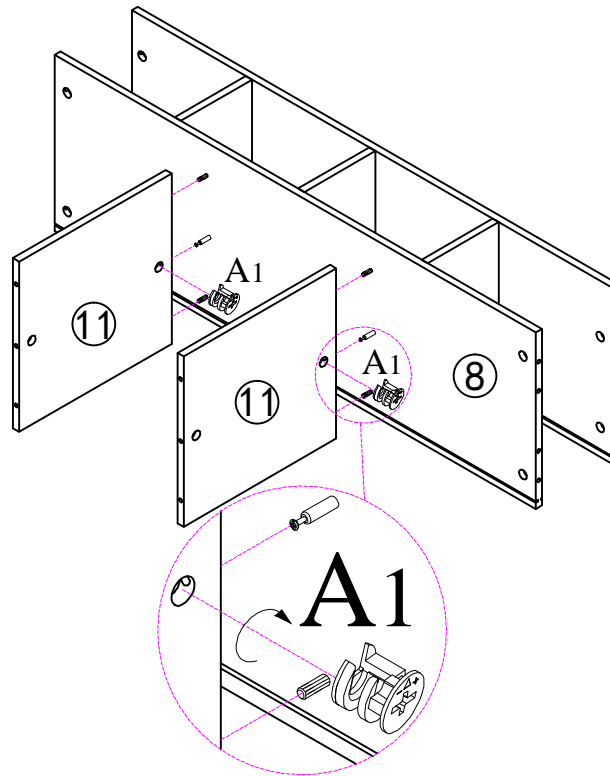

4

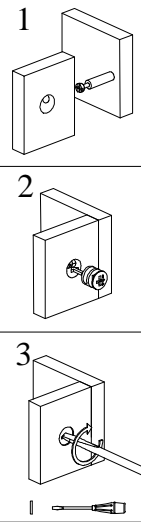
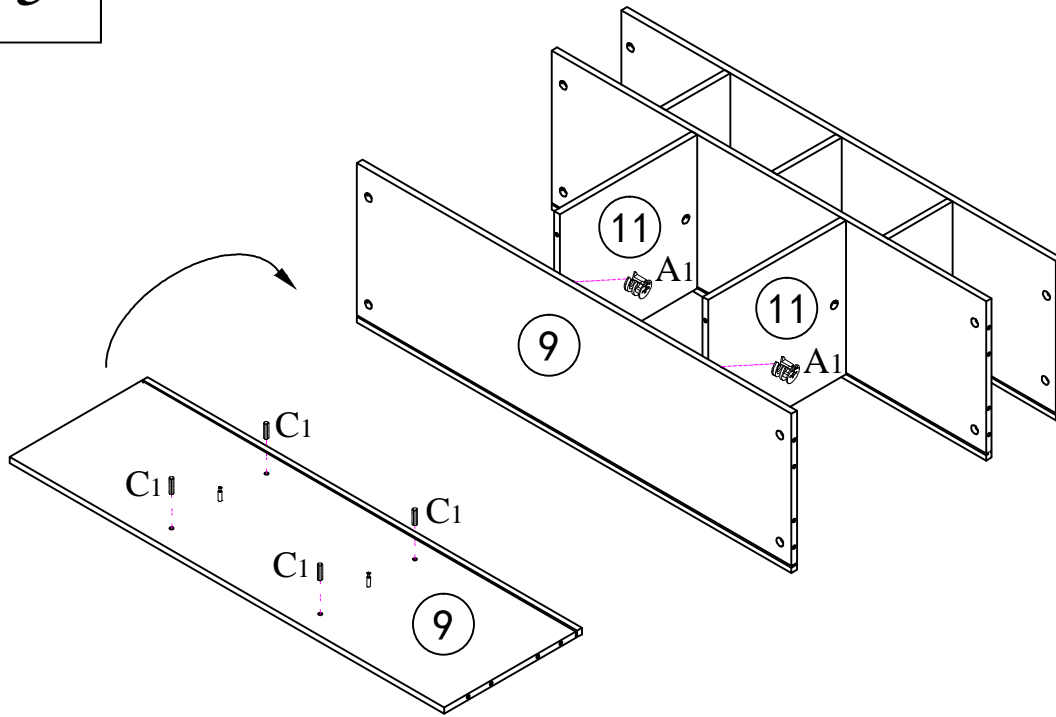

A1   
 Ø12x10mm  
 x 2

5



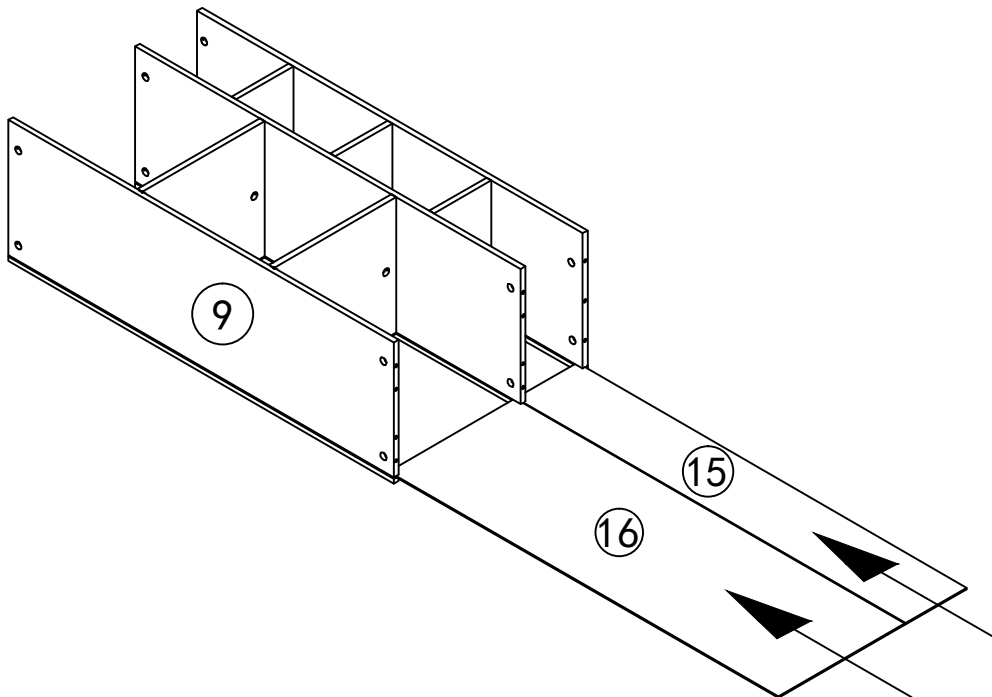

|    |   |    |  |
|----|---|----|--|
| A1 | <br>Ø12x10mm<br>x 2 | C1 | <br>Ø6 x 30mm<br>x 4 |
|----|---|----|--|

6

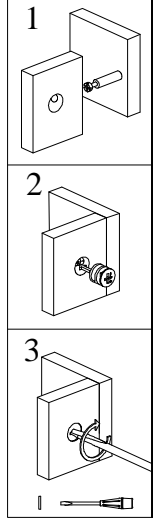
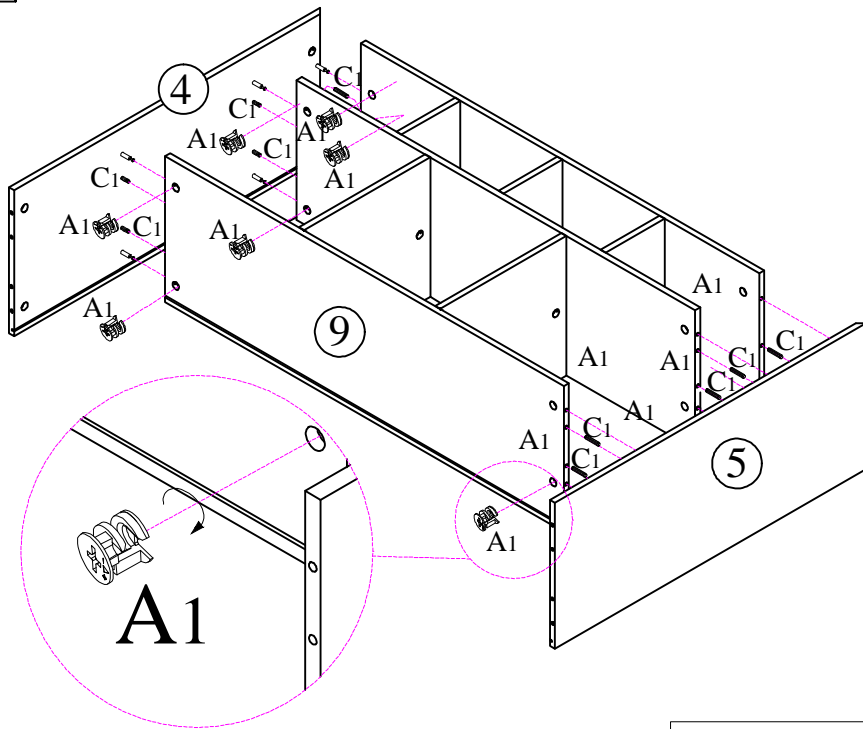

7



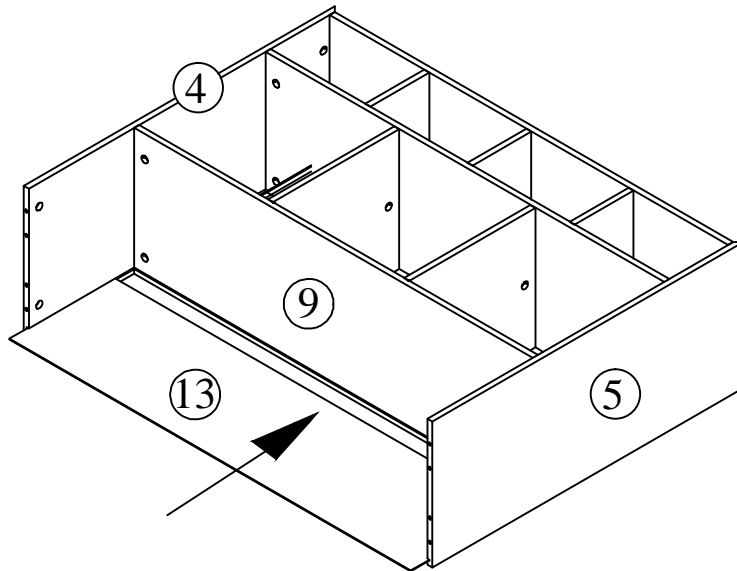

|   |   |
|---|---|
| <p>A1</p>  <p>Ø12x10mm<br/>x 12</p> | <p>C1</p>  <p>Ø6 x 30mm<br/>x10</p> |
|---|---|

8



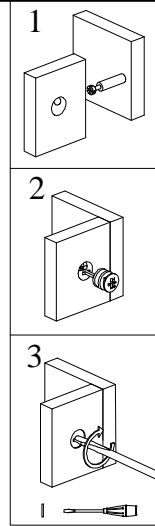
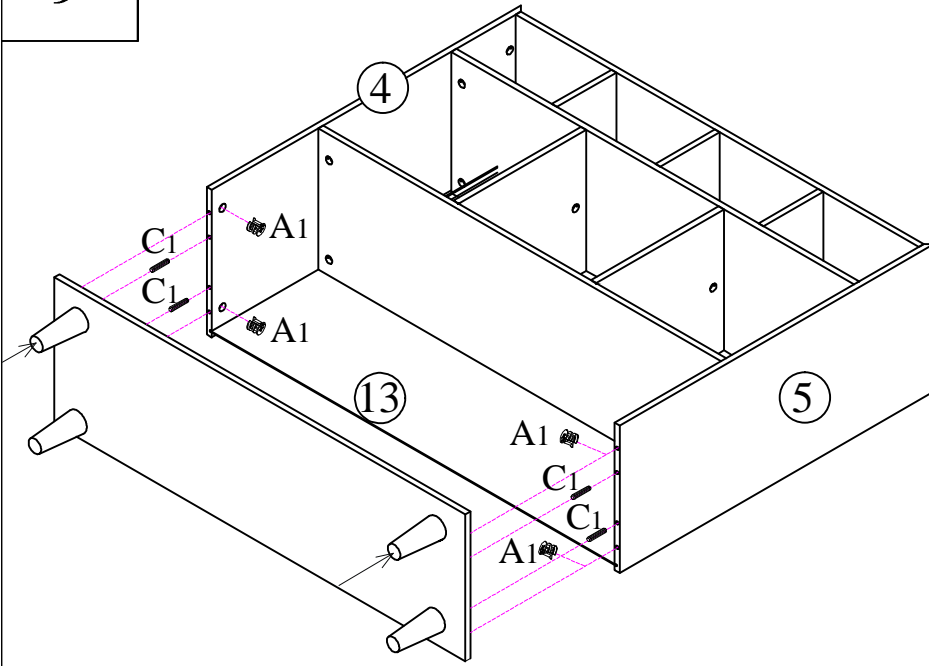

9

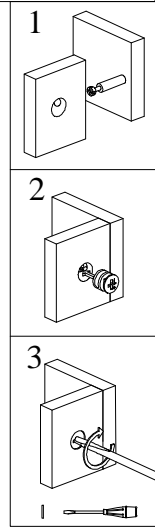
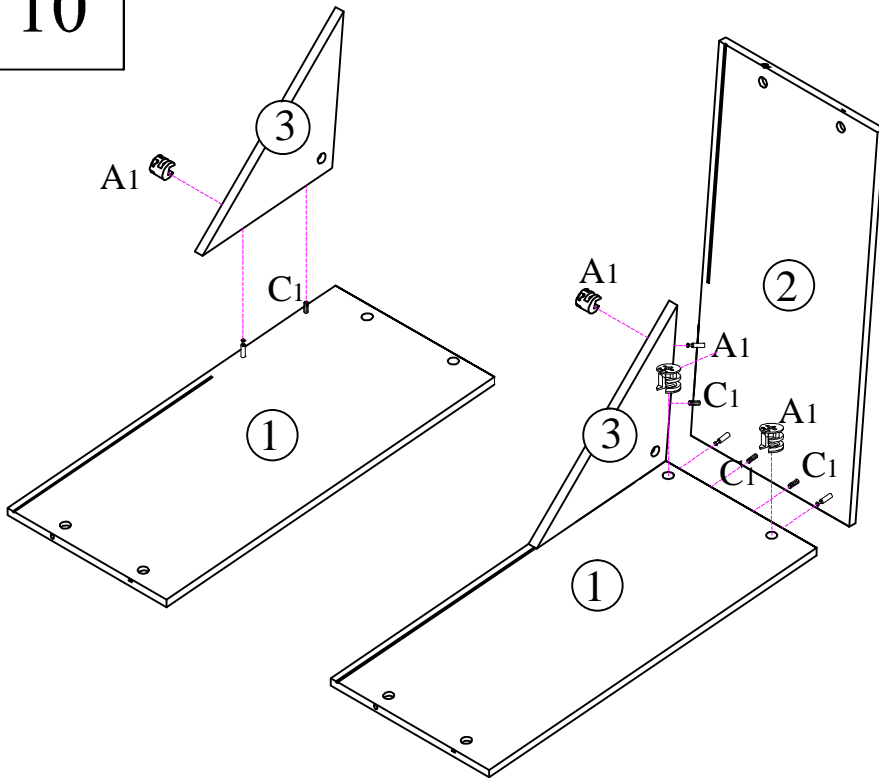

|   |   |
|---|---|
| <p>A1</p>  <p>Ø12x10mm</p> <p>x 4</p> | <p>C1</p>  <p>Ø6 x 30mm</p> <p>x4</p> |
|---|---|

10



|  |  |
|--|--|
| <p>A1</p>  <p>Ø12x10mm</p> <p>x 4</p> | <p>C1</p>  <p>Ø6 x 30mm</p> <p>x4</p> |
|--|--|

11

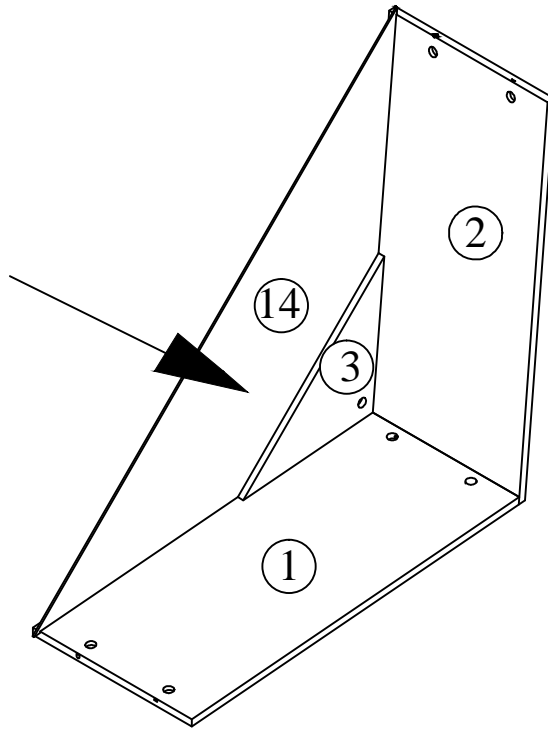

12

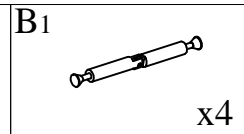
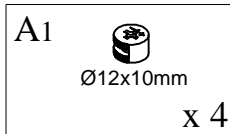
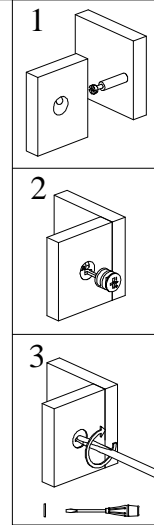
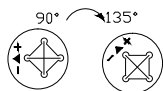
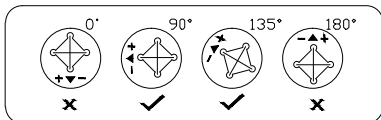
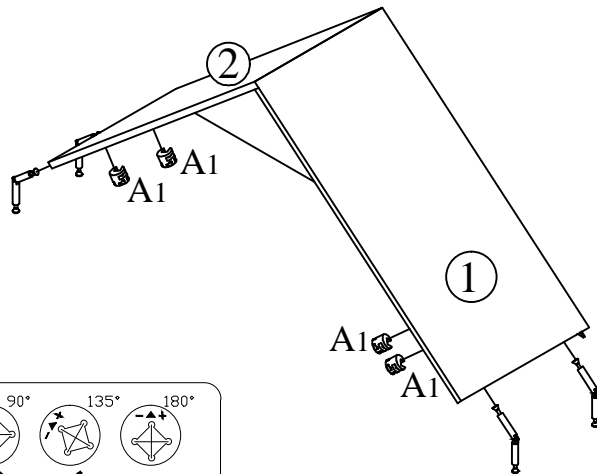



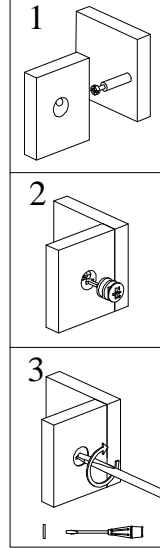
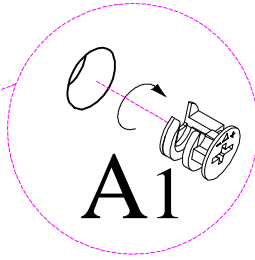
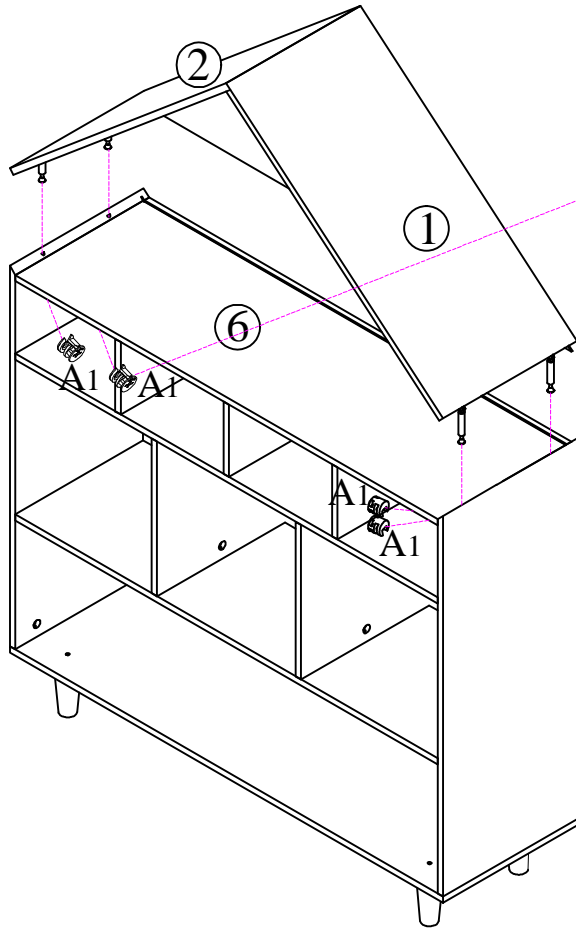

13

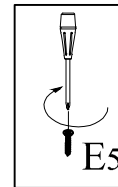
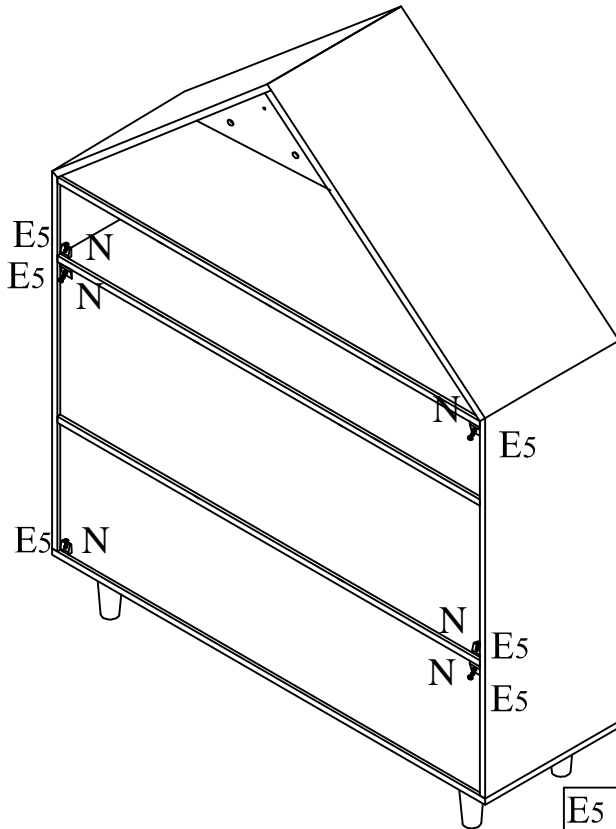

A1   
 Ø12x10mm  
 x 4

14



|   |   |
|---|---|
| E5 <br>M3x 16mm<br>x6 | N <br>x6 |
|---|---|

15

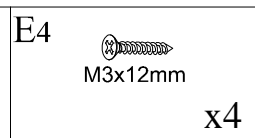
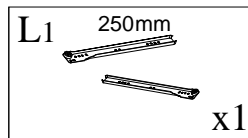
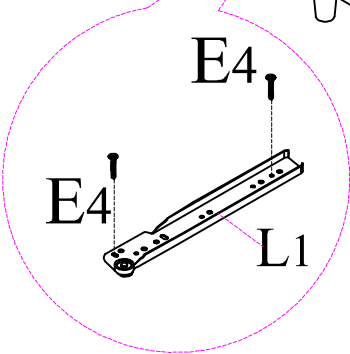
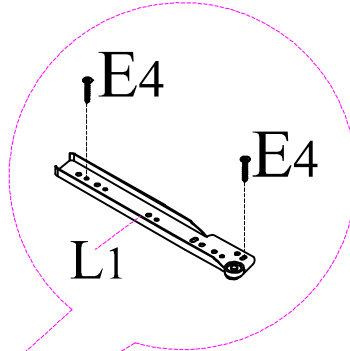
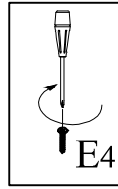
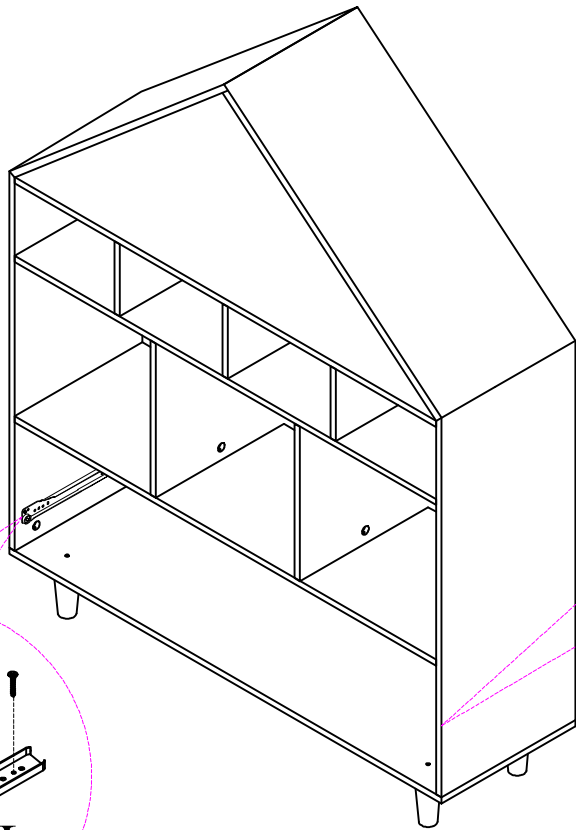

16

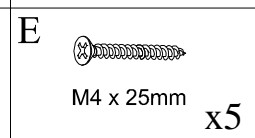
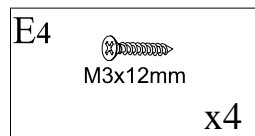
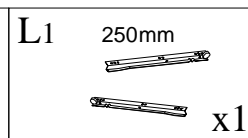
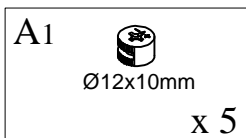
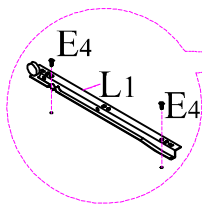
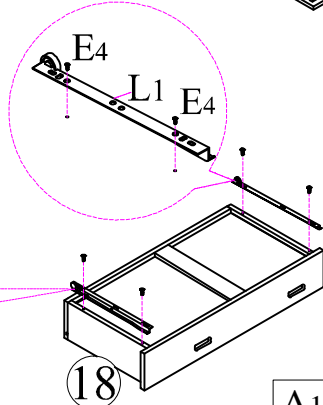
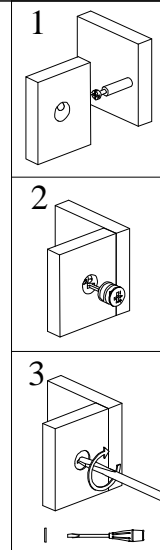
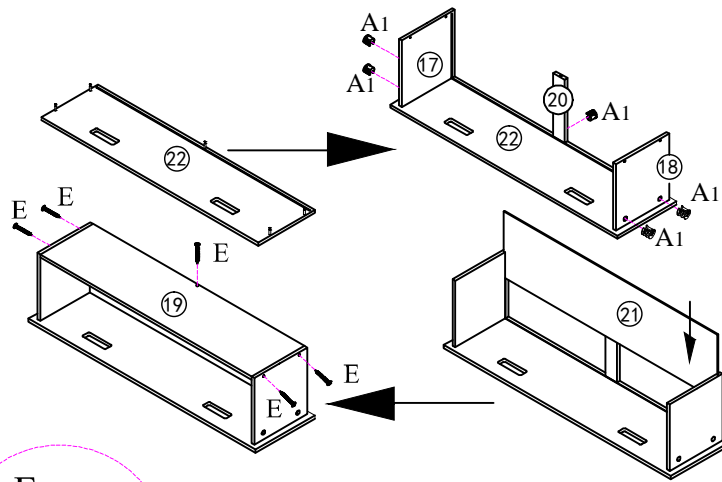
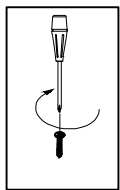

17

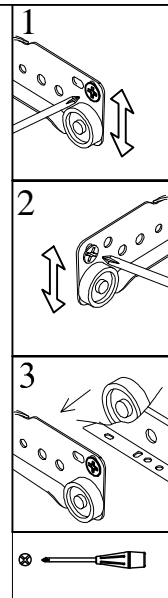
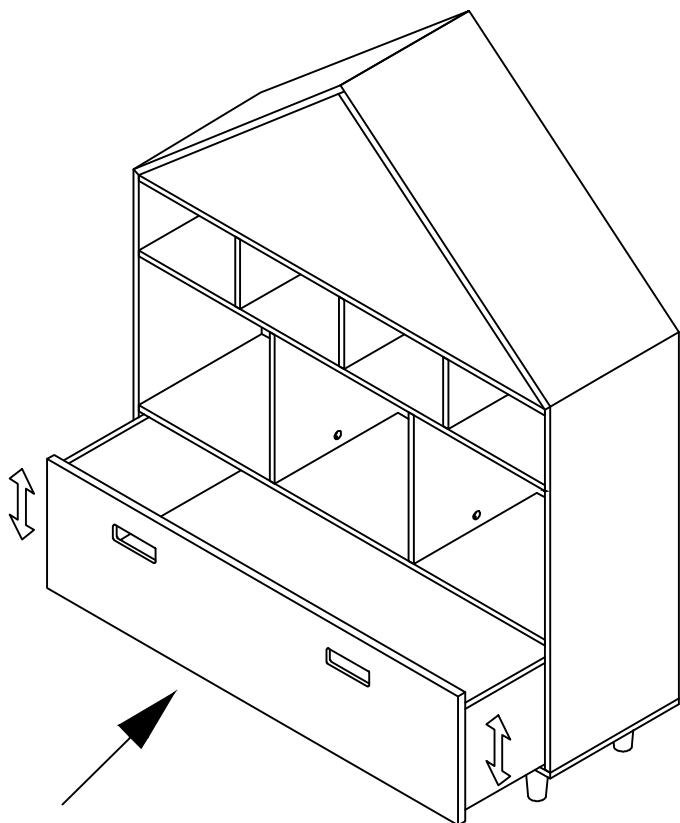

18

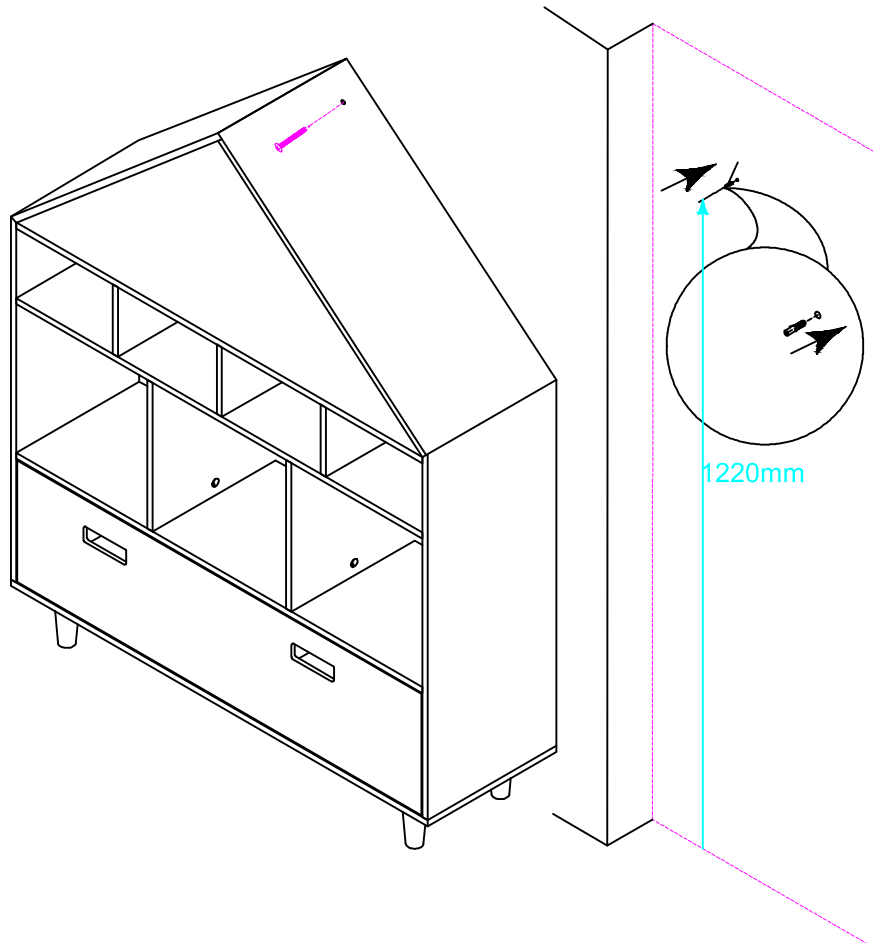

| <b>Carton</b> | <b>Reference No.</b> | <b>Quantity</b> |
|---------------|----------------------|-----------------|
| 1/1           | 1                    | 1               |
| 1/1           | 2                    | 1               |
| 1/1           | 3                    | 1               |
| 1/1           | 4                    | 1               |
| 1/1           | 5                    | 1               |
| 1/1           | 6                    | 1               |
| 1/1           | 7                    | 3               |
| 1/1           | 8                    | 1               |
| 1/1           | 9                    | 1               |
| 1/1           | 10                   | 1               |
| 1/1           | 11                   | 2               |
| 1/1           | 13                   | 1               |
| 1/1           | 14                   | 1               |
| 1/1           | 15                   | 1               |
| 1/1           | 16                   | 1               |
| 1/1           | 17                   | 1               |
| 1/1           | 18                   | 1               |
| 1/1           | 19                   | 1               |
| 1/1           | 20                   | 1               |
| 1/1           | 21                   | 1               |
| 1/1           | 22                   | 1               |
| 1/1           | Accessories          | 1               |

US



001-877-644-9366  
customerservice@aosom.com

CA



001-855-537-6088  
customerservice@aosom.ca

UK



0044-800-240-4004  
enquiries@mhstar.co.uk

DE



0049-(0)40-88307530  
service@aosom.de

FR



0033-1-84166106  
contact@aosom.fr

ES



0034-931294512  
atencioncliente@aosom.es

IT



0039-0249471447  
clienti@aosom.it