

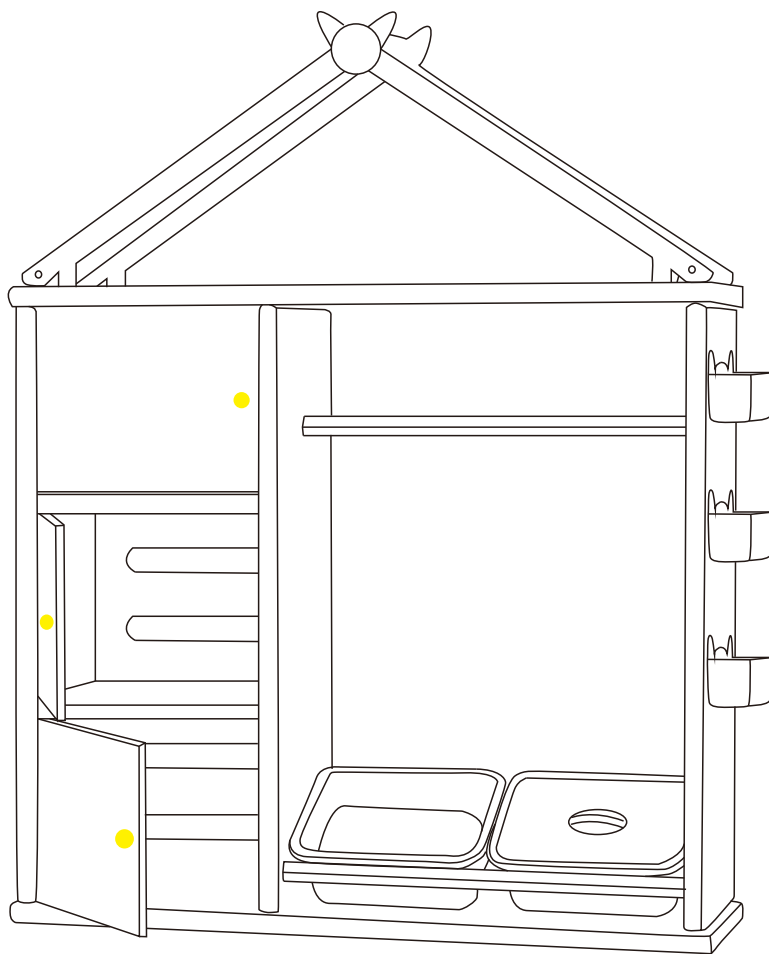

INfca082_US_CA

311-038



- * Suitable for children of 3-8 years old.
- * Max weight: 50 kg.
- * Convient aux enfants de 3 à 8 ans.
- * Poids maximum : 50 kg.



IMPORTANT, RETAIN FOR FUTURE REFERENCE: READ CAREFULLY

ASSEMBLY INSTRUCTION

⚠ WARNING: CHOKING HAZARD—Small parts. Not for children under 3 years. Only allowed for adults to install, keep children away.

⚠ Attention: Contient de petites pièces pouvant être dangereux pour les enfants moins de 3 ans. Seulement autorisé pour les adultes à installer, éloigner les enfants.

PART LIST

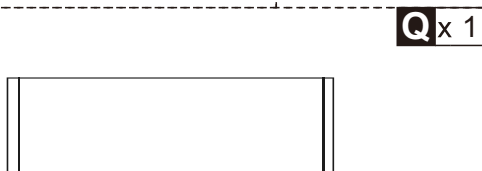
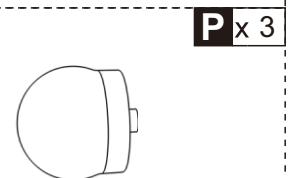
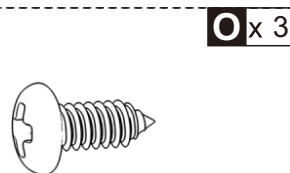
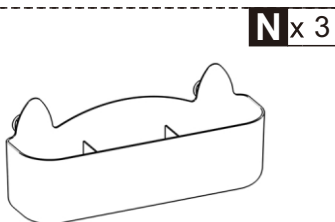
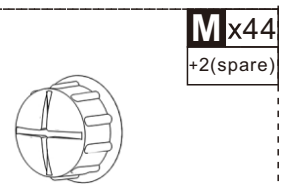
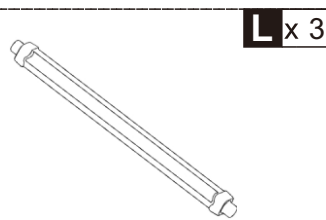
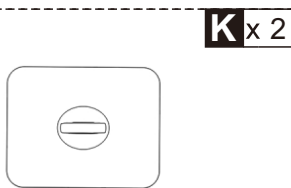
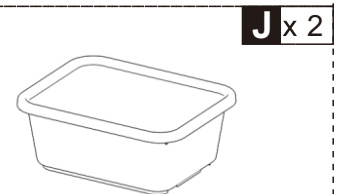
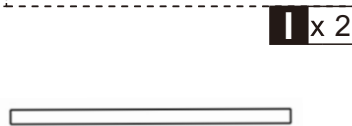
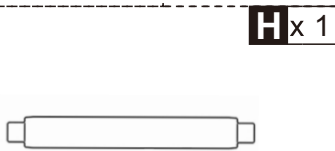
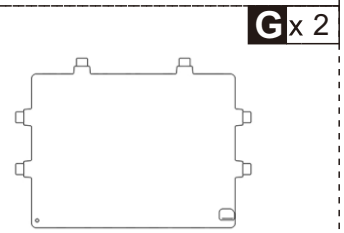
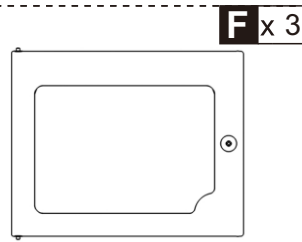
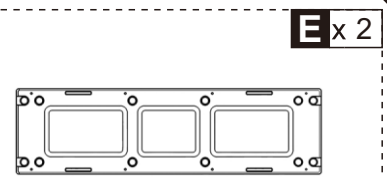
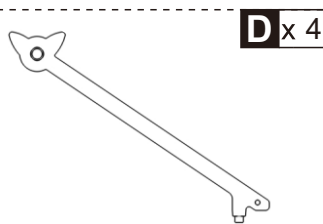
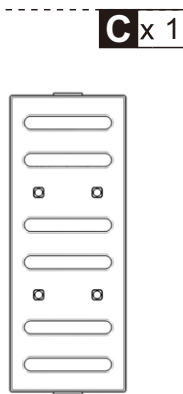
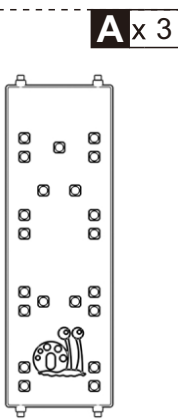

O x 3

01

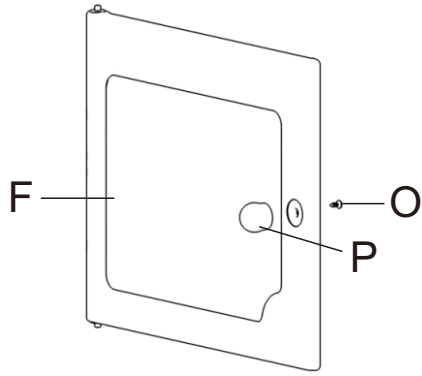

02

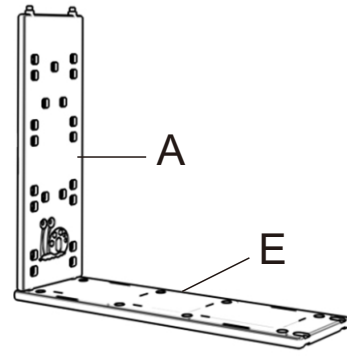

x3

03

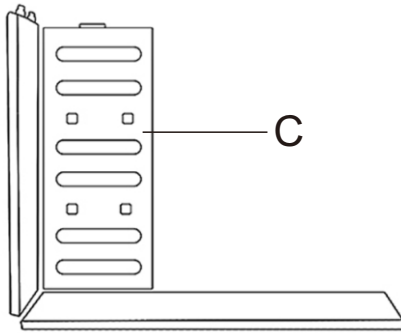

04

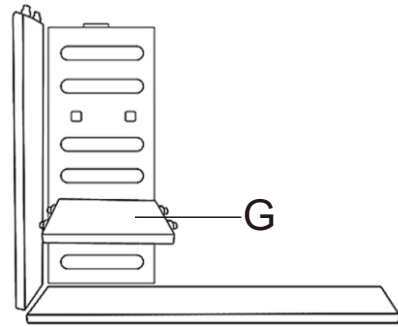

05

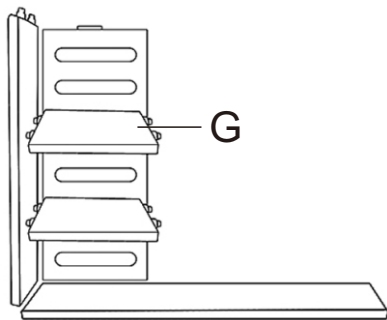

06

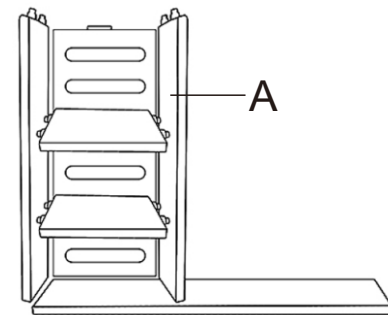

07

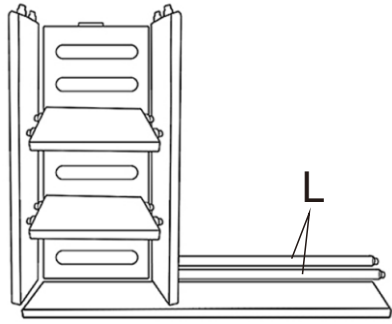

08

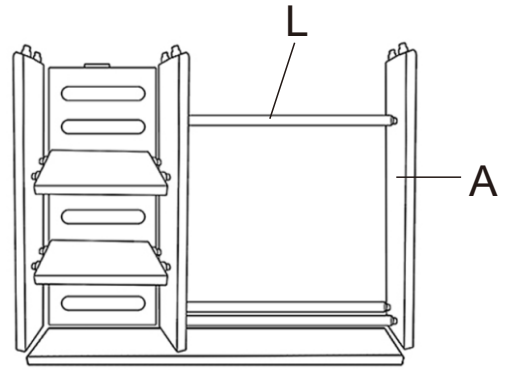

09

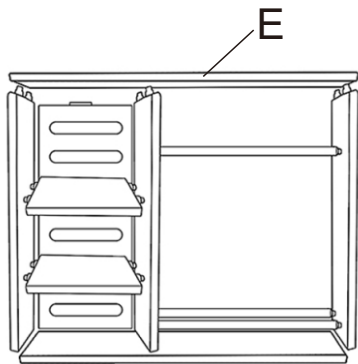

10

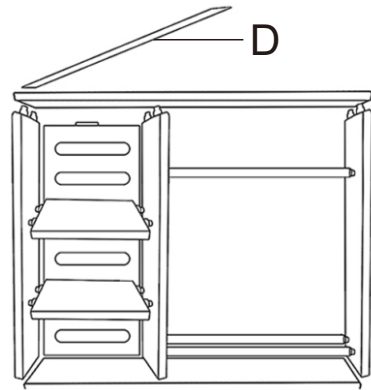

11

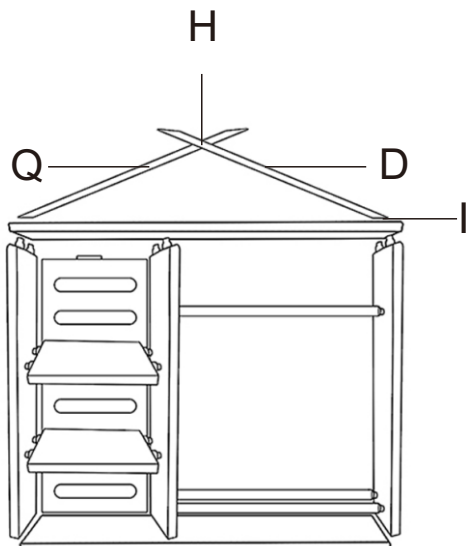

12



US



001-877-644-9366
customerservice@aosom.com

CA



001-855-537-6088
customerservice@aosom.ca

UK



0044-800-240-4004
enquiries@mhstar.co.uk

DE



0049-(0)40-88307530
service@aosom.de

FR



0033-1-84166106
contact@aosom.fr

ES



0034-931294512
atencioncliente@aosom.es

IT



0039-0249471447
clienti@aosom.it