

EN: **WARNING:** Suitable for children of 18-48months; Max weight: 50 kg.

DE: **WARNUNG:** Geeignet für Kinder im Alter von 18-48 Monate; Max. Gewicht: 50 kg.

FR: **ATTENTION:** Convient aux enfants de 18 à 48 mois; Poids maximum : 50 kg.

ES: **ADVERTENCIA:** Adecuado para los niños de 18 a 48 meses; Peso máximo: 50 kg.

IT: **ATTENZIONE:** Adatto a bambini di 18-48 mesi; Peso massimo: 50 kg.

EN_IMPORTANT, RETAIN FOR FUTURE REFERENCE: READ CAREFULLY.

FR_IMPORTANT: A LIRE ATTENTIVEMENT ET À CONSERVER POUR CONSULTATION ULTÉRIEURE.

ES_IMPORTANTE, LEA Y GUARDE PARA FUTURAS REFERENCIAS.

DE_WICHTIG! SORGFÄLTIG LESEN UND FÜR SPÄTER NACHSCHLAGEN AUFBEWAHREN.

IT_IMPORTANTE! CONSERVARE IL PRESENTE MANUALE PER FUTURO RIFERIMENTO E LEGGERLO ATTENTAMENTE.

WARNING:

1. CHOKING HAZARD—Small parts.
2. Only allowed for adults to install, keep children away.
3. To be used under the direct supervision of an adult.
4. Place it on a flat and clean floor, Check all the parts are well connected before use.

MAINTENANCE & CARE

- A. Keep all instructions and parts relating to this product for future reference.
- B. Please wipe down with a dry or damp cloth.

AVERTISSEMENT :

1. RISQUE D'ÉTOUFFEMENT - Petites pièces.
2. Installation par des adultes uniquement, tenir les enfants à l'écart.
3. À utiliser sous la surveillance directe d'un adulte.
4. Posez-le sur un sol plat et propre. Vérifiez que toutes les pièces sont bien connectées avant toute utilisation.

ENTRETIEN ET MAINTENANCE

- A. Conservez toutes les instructions et les pièces relatives à ce produit pour pouvoir vous y référer ultérieurement.
- B. Veuillez essuyer avec un chiffon sec ou humide.



FR

**Pensez à
donner ou recycler.**



Association

ou



Magasin

ou



Déchèterie

<https://quefairedemesdechets.fr>

WARNUNG:

1. ERSTICKUNGSGEFAHR-Kleine Teile.
2. Die Montage darf nur von Erwachsenen vorgenommen werden, halten Sie Kinder fern.
3. Es ist unter der direkten Aufsicht eines Erwachsenen zu verwenden.
4. Stellen Sie es auf einen flachen und sauberen Boden. Prüfen Sie, ob alle Teile vor der Verwendung gut verbunden sind.

WARTUNG & PFLEGE

- A. Bewahren Sie alle Anweisungen und Teile, die sich auf dieses Produkt beziehen, zur späteren Verwendung auf.
- B. Bitte wischen Sie es mit einem trockenen oder feuchten Tuch ab.

ADVERTENCIA:

1. PELIGRO DE ASFIXIA: Incluidas piezas pequeñas.
2. La instalación sólo se puede realizar por los adultos, mantenga a los niños alejados al instalar el producto.
3. El producto debe ser utilizado bajo la supervisión directa de un adulto.
4. Colóquelo sobre un piso plano y limpio. Verifique si todas las piezas estén conectadas adecuadamente antes de utilizarlo.

MANTENIMIENTO Y CUIDADO

- A. Guarde todas las instrucciones y piezas relativas juntas con este producto para las referencias futuras.
- B. Límpielo con un paño seco o humedecido.

AVVERTENZE:

1. RISCHIO DI SOFFOCAMENTO — Parti piccole.
2. Consentito solo agli adulti di installare, tenere lontani i bambini.
3. Da utilizzare sotto la diretta supervisione di un adulto.
4. Posizionarlo su una superficie piana e pulita, controllare che tutte le parti siano connesse correttamente prima dell'uso.

MANUTENZIONE & CURA

- A. Conservare tutte le istruzioni e le parti relative a questo prodotto per riferimenti futuri.
- B. Si prega di pulire passando un panno asciutto o inumidito.

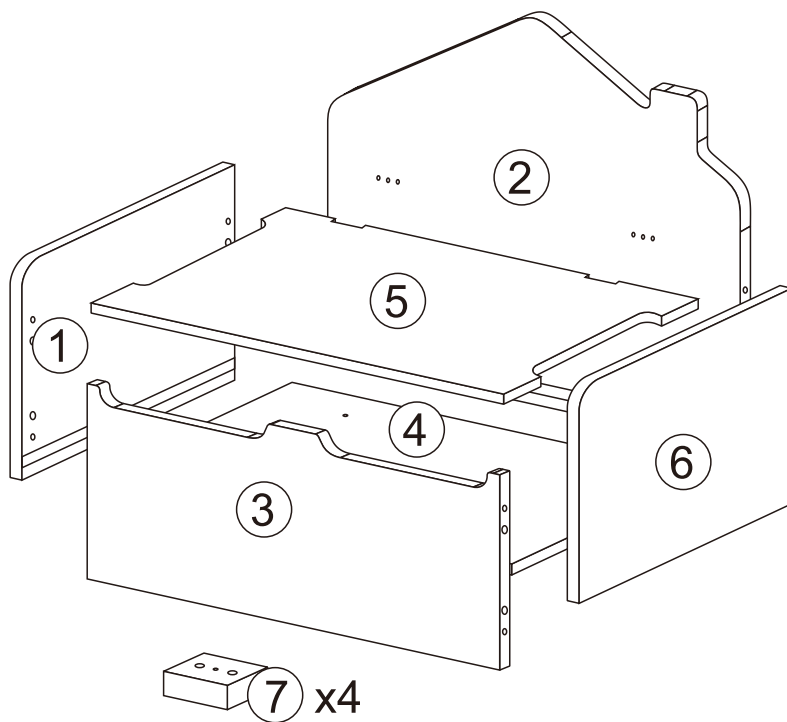

HARDWARE

A x 4 [Screw icon]	B x 12 +1(spare) [Screw icon]	C x 4 [Screw icon]	D x 16 +1(spare) [Rod icon]	E x 8 +1(spare) [Screw icon]
F x 8 +1(spare) [Washer icon]	G x 2 [Bracket icon]	H x 1 [Block icon]	I x 1 [Bracket icon]	
J x 1 [Bracket icon]	K x 1 [Washer icon]	L x 5 +1(spare) [Screw icon]	M x 1 [Screwdriver icon]	

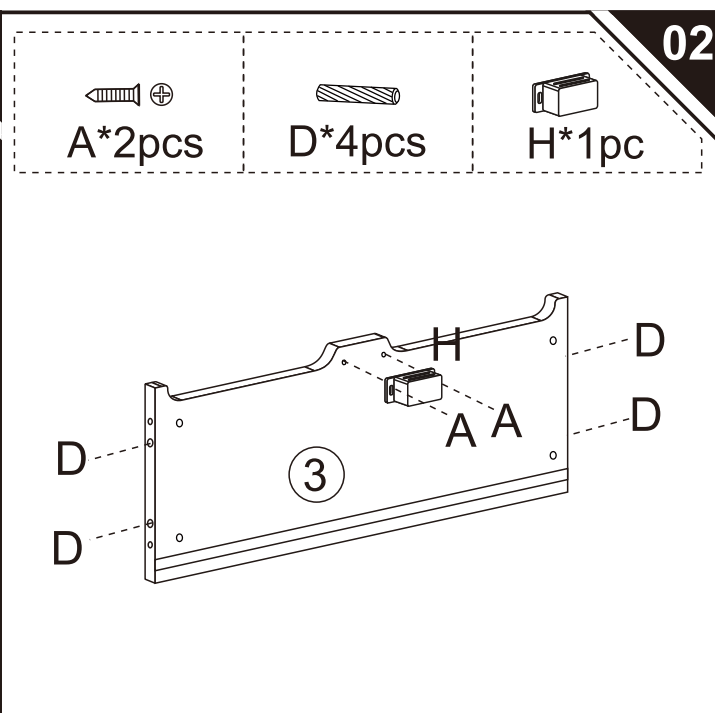
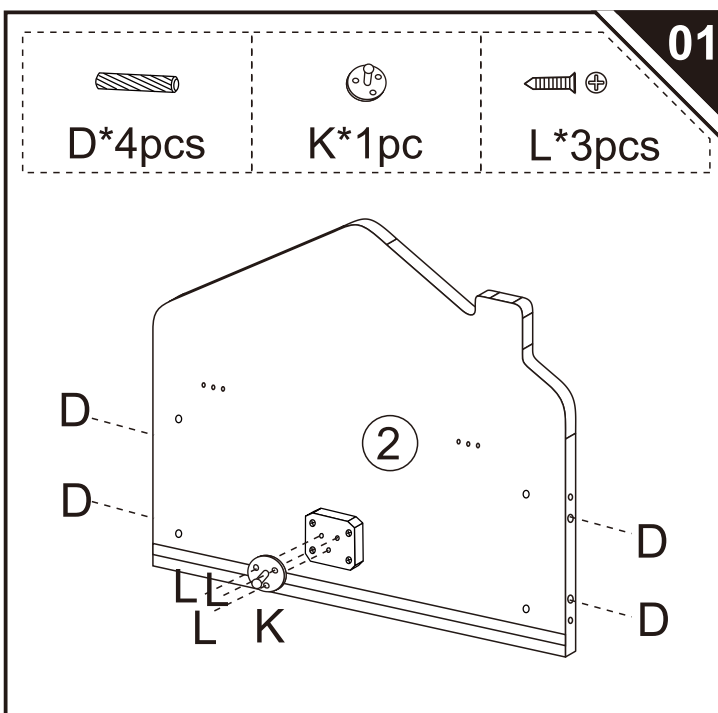

03

E*4pcs

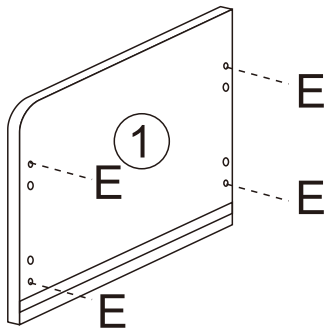

04

C*4pcs

D*8pcs

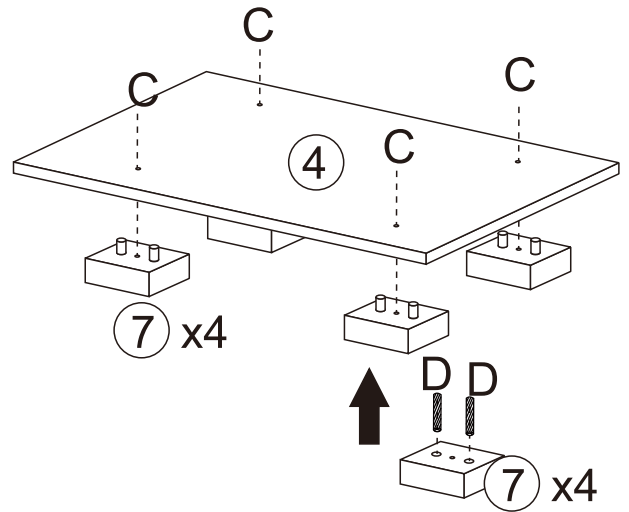

05

E*4pcs

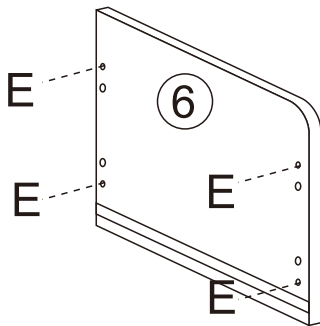

06

A*2pcs

B*6pcs

G*2pcs

I*1pc

J*1pc

L*2pcs

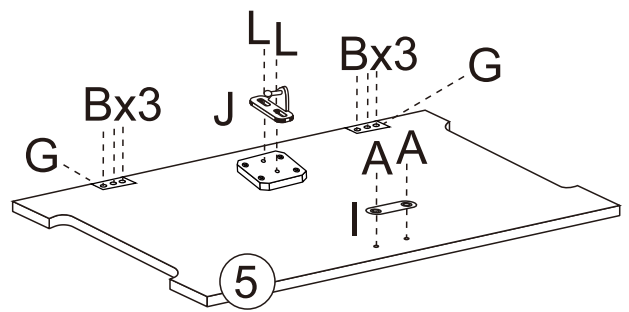

07

F*8pcs

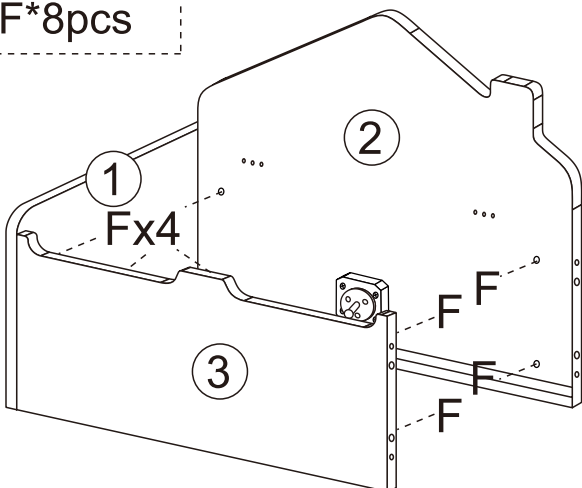

08

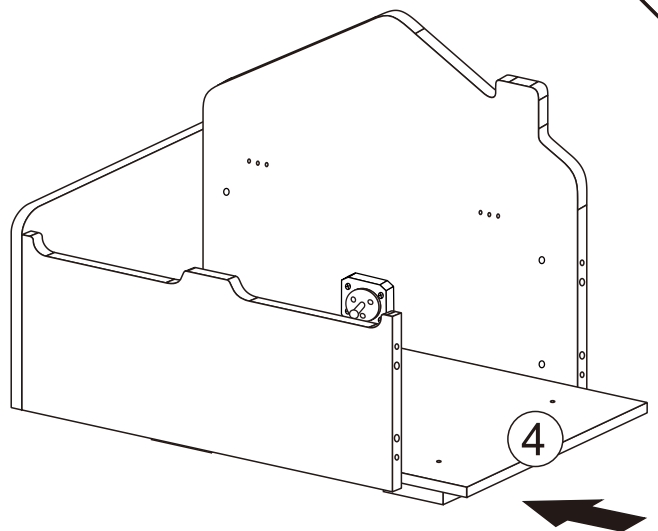

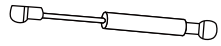

M*1pc

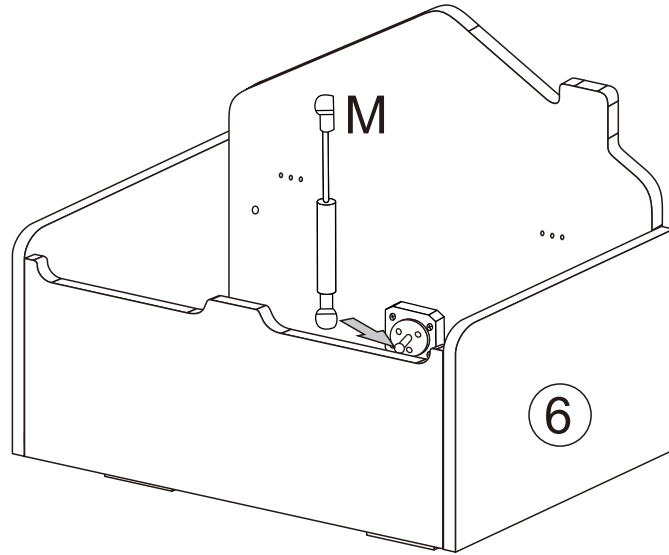

B*6pcs

