

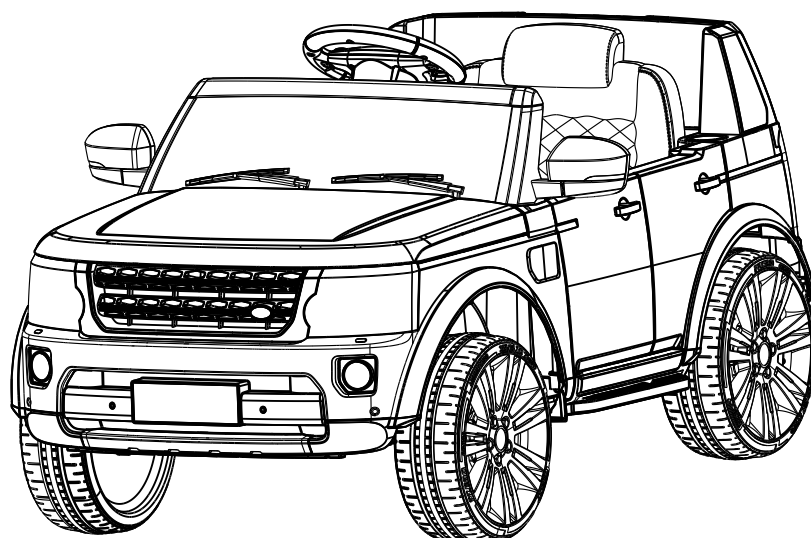

INfdb001V01_US_CA

370-140V80

Children's electric cars



WARNING:

The toy is to be assembled by an adult.
This toy is unsuitable for children under
3 years due to its maximum speed.

IMPORTANT, RETAIN FOR FUTURE REFERENCE: READ CAREFULLY

ASSEMBLY INSTRUCTION

Specifications:	
Battery:	12V 4.5Ah (6-FM-4.5 (Ah)) *1
Motor:	Steering motor: 12V 12V (motor 390) *2
Suitable ages:	37-96 months
Maximum weight:	28KG
Speed :	1. 8-3.7KM/h
Power way:	Charging type
Use of time:	Charg: 8-12 hours ; Use: 1-2 hours
Charger:	Input AC 110~ 240V, output DC 12 V 500mA

WARNING

1.The pictures in this instruction is only for explaining the operation and structure of the product, when there's any difference with the real product, please confirm with the real product.

2.In order to improve the quality of the product,we may amend some structure or appearance of the product without notification.Thank you for your understanding.

FOR THE SAFETY OF YOUR CHILD, PLEASE READ ALL WARNINGS AND ASSEMBLY/USE INSTRUCTIONS. KEEP THIS GUIDE FOR FUTURE REFERENCE.

- ADULT ASSEMBLY REQUIRED. The product contains small parts, which are for adult assembly only. keep small children away when assembling.
- always remove protective material and poly bags and dispose before assembly.
- never leave child unattended. direct adult supervision is required.
- always keep child in view when child is in vehicle.
- Keep Children within Safe Riding Areas:
 - Never use in roadways, near motor vehicles, on lawn space, on or near steep inclines or steps, swimming pools or or any other dangerous area.
- Use the toy only on flat surfaces. Such as inside your house, garden or playground.
- Never use in the dark. A child could encounter unexpected obstacles and have an accident. Operate the vehicle only in the daytime or a well-lit area.
- Please avoid running on sand or any other rough ground.
- always wear shoes.
- always sit on the seat.
- this toy has no brake.
- It is prohibited to change the circuit or add other electric parts
- Inspect wires and connections of the vehicle periodically.
- Do not let any child touch the wheels or be near them when the car is moving.
- This vehicle has adjustable play seat belts. Please instruct children how to tie the safety belt before using, guarantee the security.

STORAGE BATTERY INFORMATION AND MAINTENANCE

- Please charge 8 to 12 hours before first time use.
- Please use the suitable adapter to charge storage battery, otherwise the ride-on will be damaged.
- Please charge the car once the speed is slower than normal, otherwise it will decrease storage battery life.
- Please fully charge the battery before you put your ride-on away, and remember to recharge the battery every 30 days. This will ensure the normal use of the battery, otherwise, the battery might not hold a charge without proper maintenance.
- Batteries may leak fluids that can cause chemical burn injury or ruin your product.
- To avoid battery leakage: Do not mix old and new batteries or batteries of different types: alkaline, standard (carbon-zinc) or rechargeable (nickel-cadmium).
- Insert batteries as indicated inside the battery compartment. Remove batteries during long periods of non-use.
- Always remove exhausted batteries from the product. Dispose of batteries safely. Do not dispose of batteries in a fire. The batteries may explode or leak.
- Never short-circuit the battery terminals.
- Non-rechargeable batteries are not to be recharged.
- Use only batteries of the same or equivalent type as recommended.
- Do not charge non-rechargeable batteries.
- Remove rechargeable batteries from the product before charging.
- If removable rechargeable batteries are used, they are only to be charged under adult supervision
- Every single charging can not go over 20 hours. Both charger and storage batteries will occur mildly warm during charging. Do not use mal-functioned adapter or storage battery unless they are repaired.
- Charger and storage batteries are not considered as toys.
- Please make periodical inspection for storage battery, especially for adapter wires and plugs.
- Please turn off the switch when the ride-on is not in use. Please do a full charge after long periods of inactivity.
- Charge in well ventilated, dry place. Do not open the battery or the charger.
- Tighten the screws with a screwdriver. DO NOT over tighten

Disposal Of Battery:

1. Your sealed lead-acid battery must be recycled or disposed of in an environmentally sound manner.
2. Do not dispose of your lead-acid battery in a fire. The battery may explode or leak.
3. Do not dispose of a lead-acid battery in your regular, household trash. The incineration, land filling or mixing of sealed lead-acid batteries with house-hold trash is prohibited by law.

PREVENT FIRE AND ELECTRIC SHOCK:

- Use the only rechargeable battery and charger supplied with your vehicle.
- NEVER substitute the battery or the charger with another brand. Using another battery or charger may cause a fire or explosion.
- Do not use the battery or charger for any other product. Overheating, fire or explosion could occur.
- NEVER modify the electric circuit system. Tampering with the electric system may cause a shock, fire or explosion or may permanently damage the system.
- Do not allow direct contact between battery terminals. Fire or explosion can occur.
- Do not allow any type of liquid on the battery or its components.
- Explosive gasses are created during charging. Do not charge near heat or flammable materials. Charge the battery in a well- ventilated area ONLY.
- NEVER pick up the battery by the wires or charger. Damage can occur to the battery and may cause a fire. Pick up the battery by the case ONLY.

Charge the battery in a dry area ONLY.

●Battery posts, terminals and related accessories contain lead and lead compounds, chemicals known to the State of California to cause cancer and reproductive harm. Wash hands after handling.

●Do not open the battery. Battery contains lead acid and other materials that are toxic and corrosive.

●Do not open the charger. Exposed wiring and circuitry inside case may cause electric shock.

ONLY adults may handle or charge the battery. NEVER allow child to handle or charge the battery. Battery is heavy and contains lead acid (electrolyte).

●Do not drop the battery. Permanent damage to the battery could occur or cause serious injury.

●Before charging the battery, check for wear or damage to the battery, charger, its supply cord and the connectors. DO NOT charge the battery if any damage to parts has occurred.

Do not allow the battery to drain completely. Recharge the battery after each use or once a month if not used regularly.

●Do not charge battery upside down.

●Always secure the battery with the bracket. Battery can fall out and injure a child if vehicle tips over.

●It is parents' responsibility to check main parts of the toy before using, Must regularly examine for potential hazard, such as the battery, charge, cable or cord, plug, screws are fastening enclosure of other parts and that in the event of such damage, the toy must not be until that damage had been properly removed. Make sure the plastic parts of the vehicle are not cracked or broken.

●Occasionally use a lightweight oil to lubricate moving parts such as wheels.

●Park the vehicle indoors or cover it with a tarp to protect it from wet weather.

●Keep the vehicle away from sources of heat, such as stoves and heaters. Plastic parts may melt.

●Recharge the battery after each use. Only an adult can handle the battery. Recharge the battery at least once a month when the vehicle Raider is not being used.

●Do not wash the vehicle with a hose. Do not wash the vehicle with soap and water. Do not drive the vehicle in rainy or snowy weather. Water will damage the motor, electric system and battery.

●Clean the vehicle with a soft, dry cloth. To restore shine to plastic parts, use a non-wax furniture polish. Do not use car wax. Do not use abrasive cleaners.

●Do not drive the vehicle in loose dirt, sand or fine gravel which could damage moving parts, motors or the electric system.

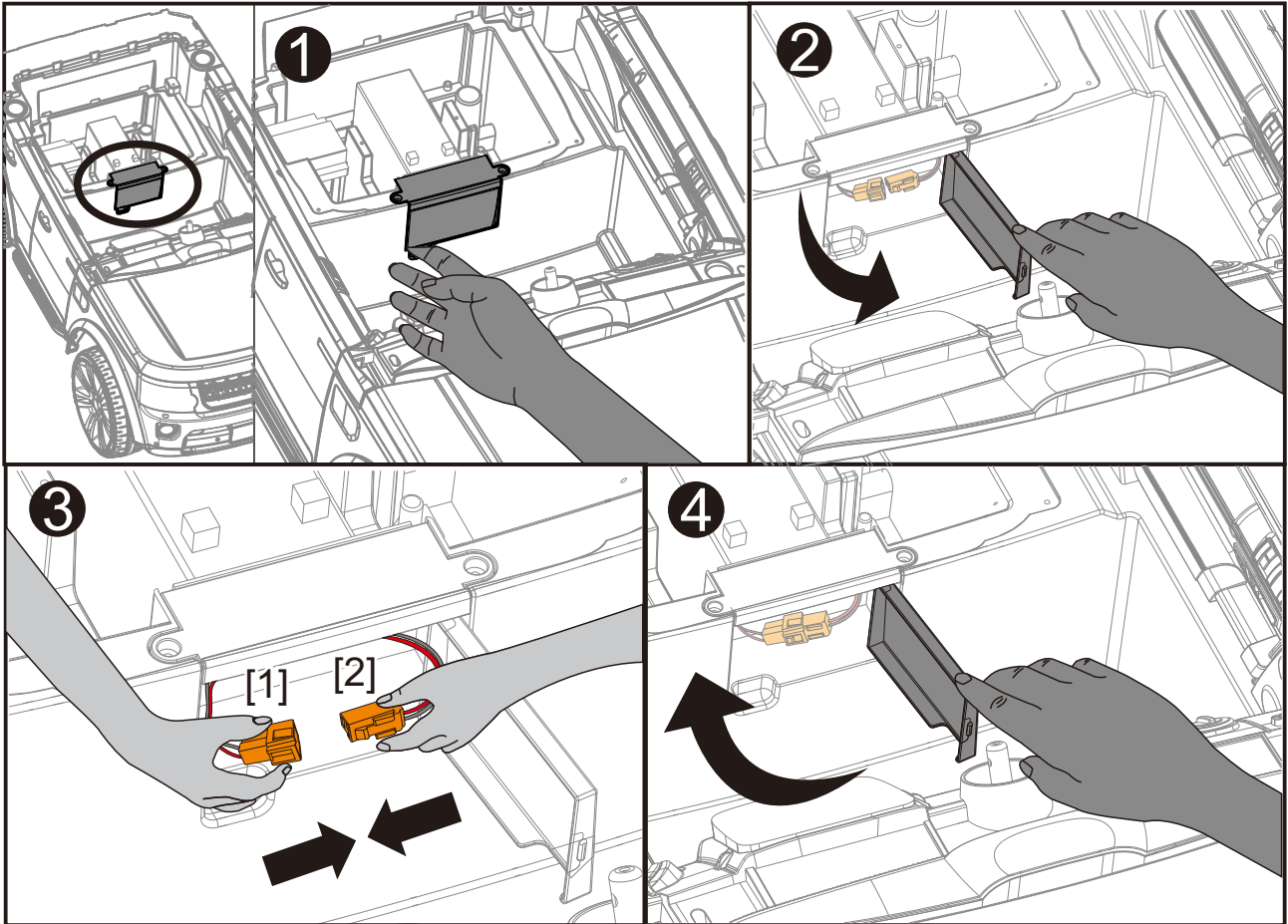

●When not using, all the electrical source should be turn off. Turn off the power switch and disconnect the battery connection.

Preparation before installation: Power-on

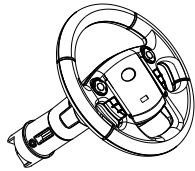

- 1 & 2: Please find and open the Charging hole cover as shown in figure.
 3. Connect the terminal [1] and [2].
 4. Close the Charging hole cover.

Parts List

NO.	QTY	PICTURE	NO.	QTY	PICTURE
①	1		②	1	
		A (Steering Wheel)			B (Instruction Book)

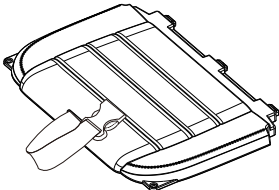
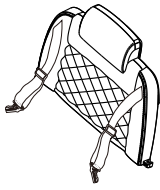
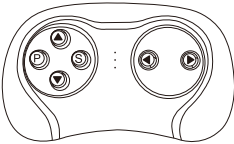
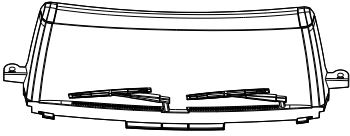
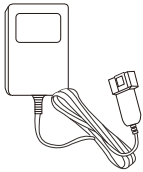
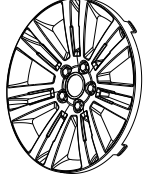
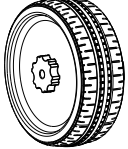
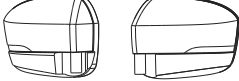
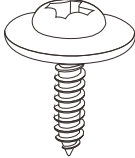
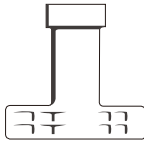
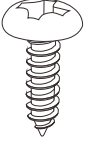
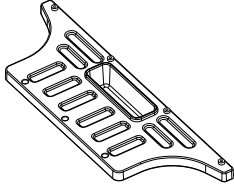
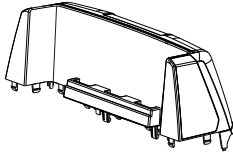
NO.	QTY	PICTURE	NO.	QTY	PICTURE
③	1	 C (Seat)	④	1	 D (Backrest)
⑤	1 (optional)	 E (Remote control)	⑥	1	 F (Wind deflector)
⑦	1	 G (Charger)	⑧	4	 H (Wheel Cover)
⑨	4	 I (Wheel)	⑩	1 set	 J (Rear view mirror)
⑪	2	 K (Padded screw)	⑫	2	 P (M8 Spanner)
⑬	11	 L (4*12 self-tapping screw)	⑭	1	 M (Rear bracket)
⑮	1	 N (Rear frame)			

*Photos are for reference ONLY.

Installation Steps

Step 1: Install rear bracket

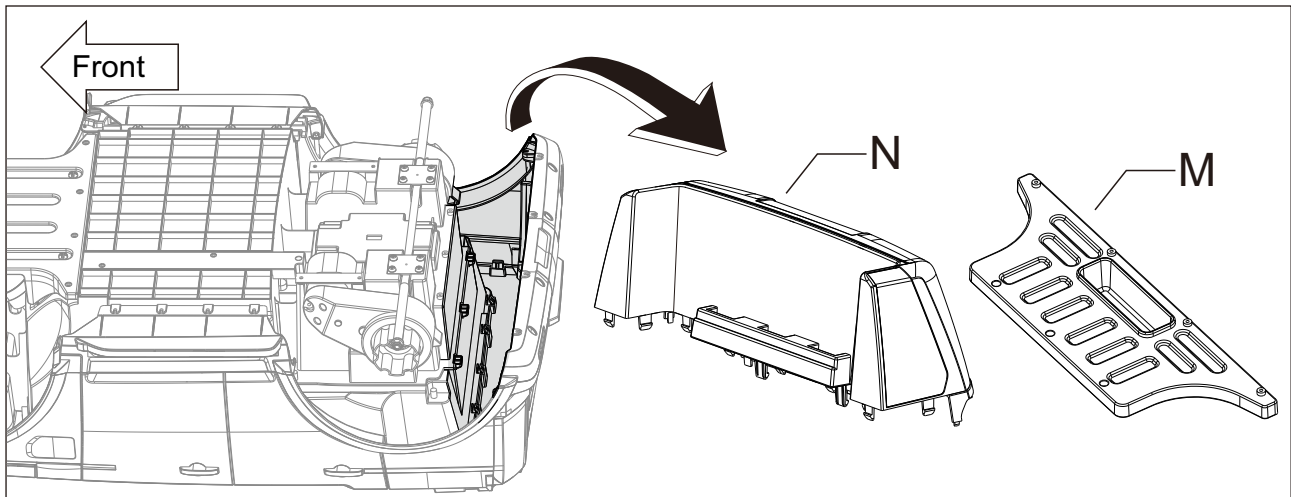

1. Flip vehicle over and lay it on a level surface. Remove all parts and packaging from within the vehicle body.

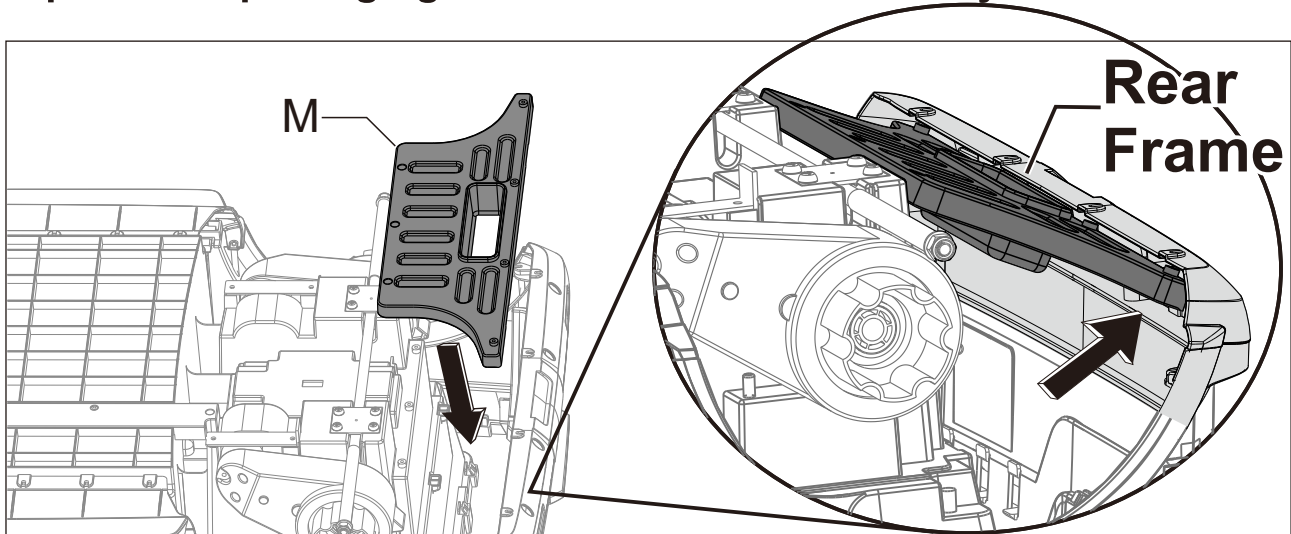

2. Insert the part M rear bracket underneath the rear frame.

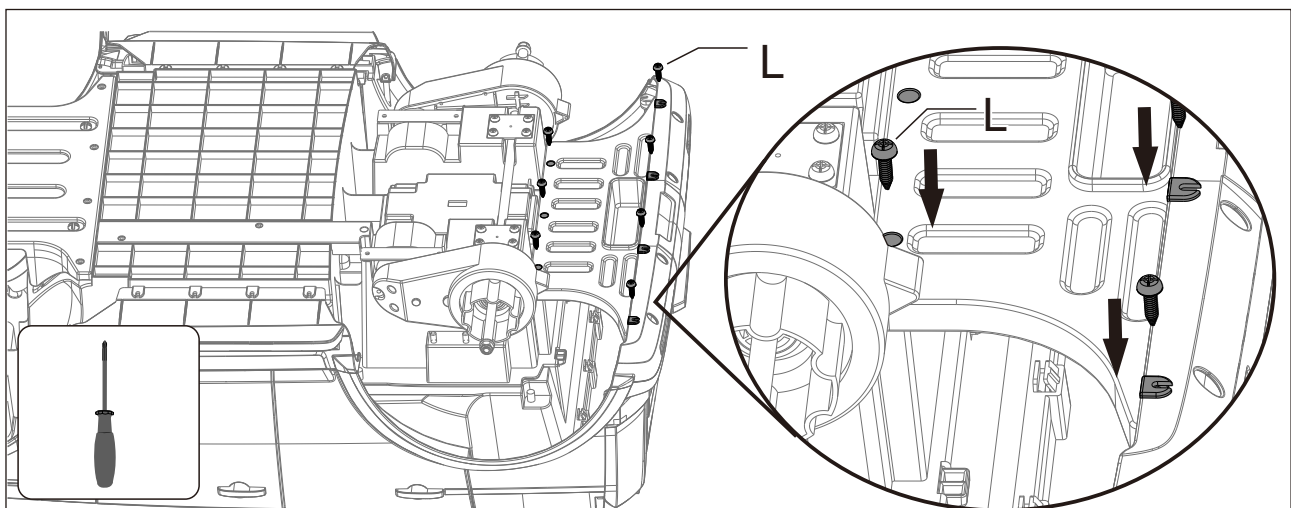

3. Secure part M rear bracket with seven part L screws.

Step 2: Install the gear box

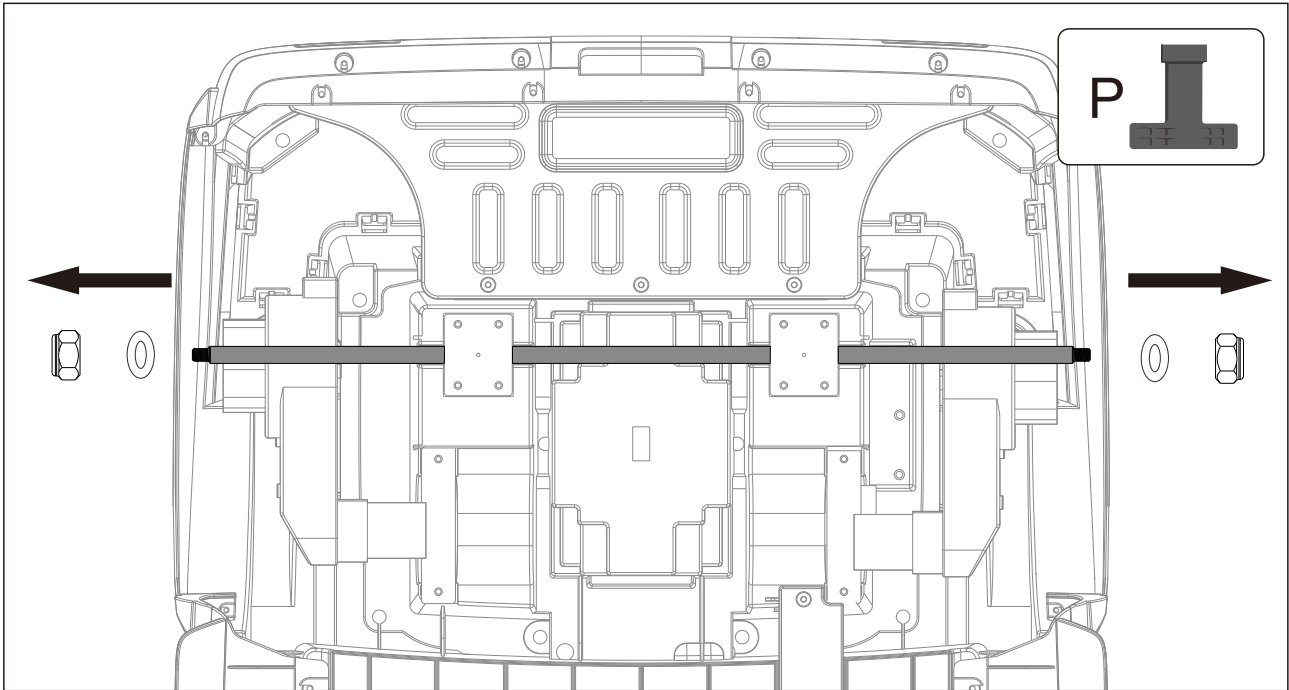

1. First, use the M8 wrench to unscrew the nuts on the rear axle and remove the washer.

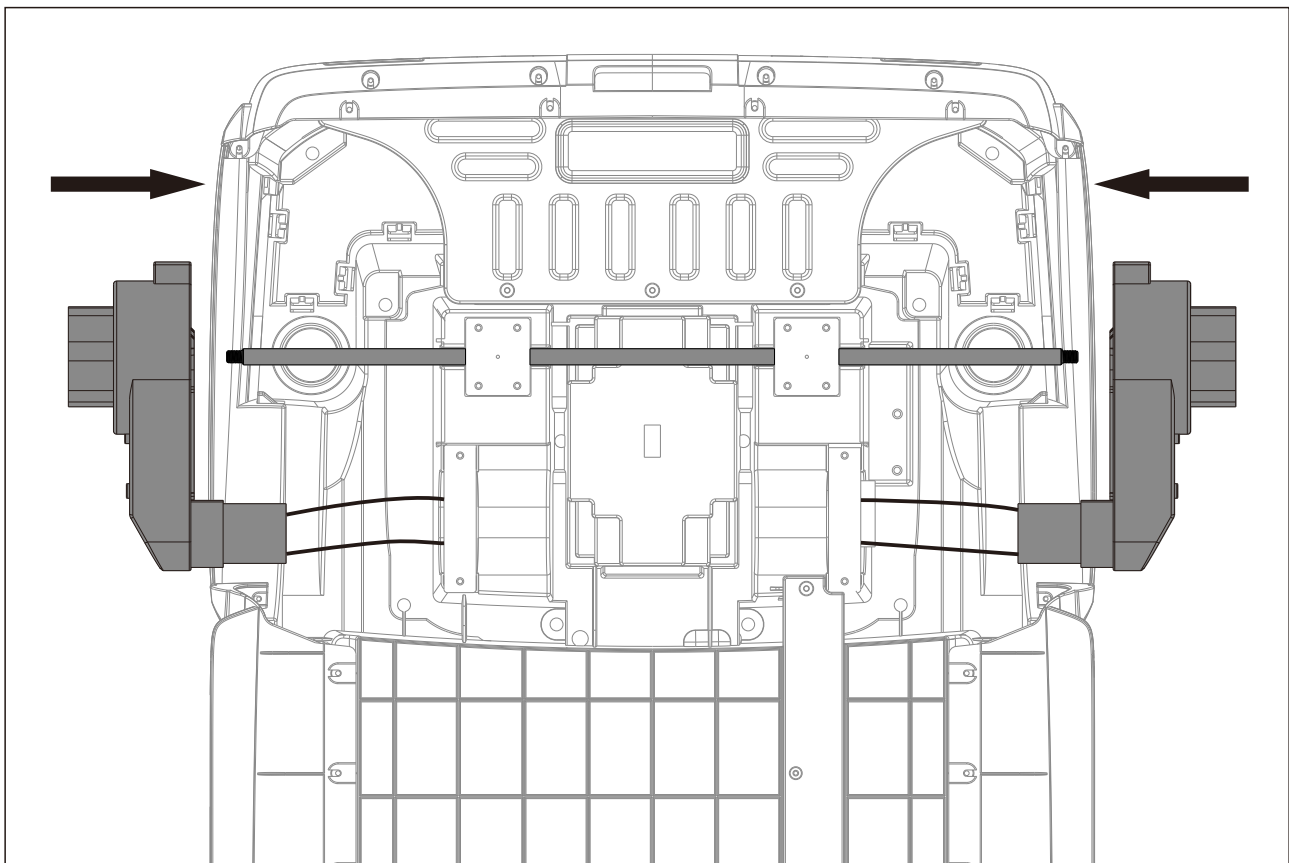

2. Then, install the left and right motors on the rear axle.

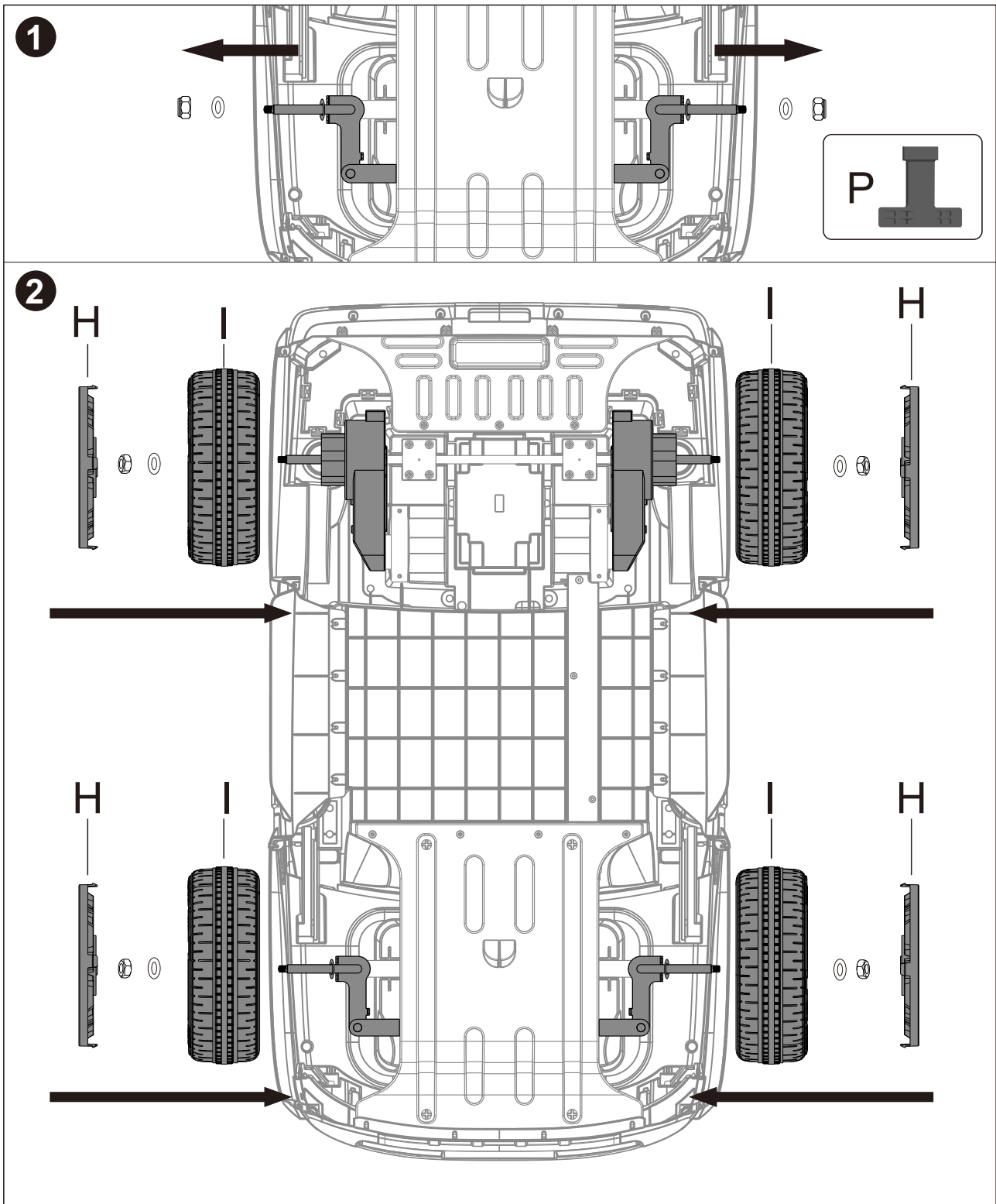

Step 3: Install the wheel

1. Remove the nut and washer at two end of front axle firstly.
2. Install the I(wheel), washer, screw, H (wheel cover) on each front axle and rear axle in turn as shown (attention: the left and right reserved length of the rear axle should be consistent; all wheel's gear shaft should toward the car body; align and press the buckle of the wheel cap with the grooves of the wheel to fix it).

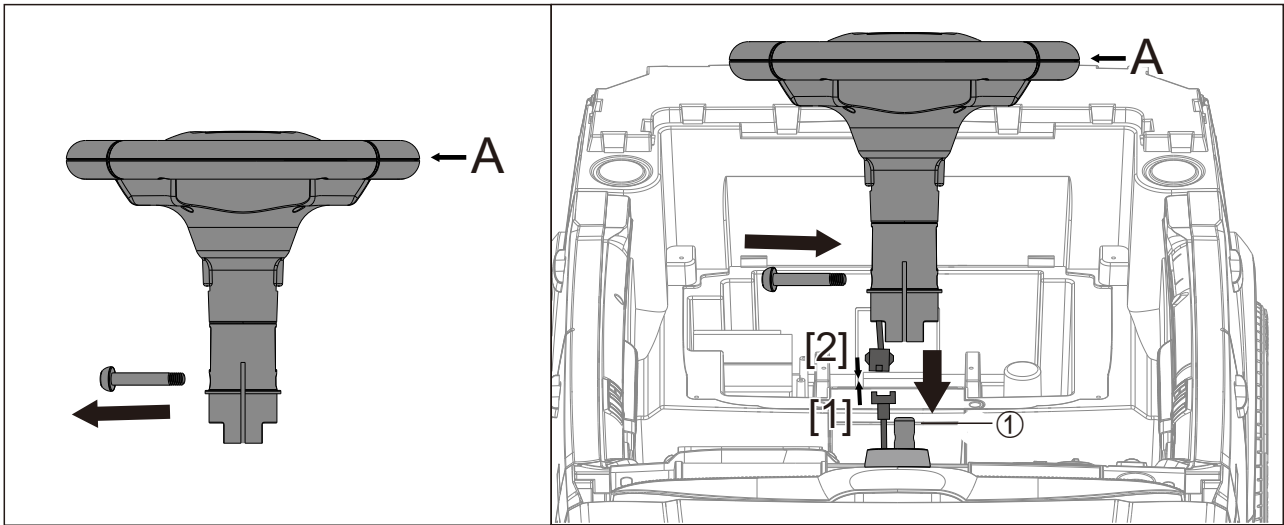

Step 4: Install Steering Wheel

1. Remove the screw from the A (steering wheel) firstly.
2. Connect [1],[2] terminal first, place and fix A(steering wheel)on ① steering yoke as shown in figure. then insert the screw back to the A (steering wheel).

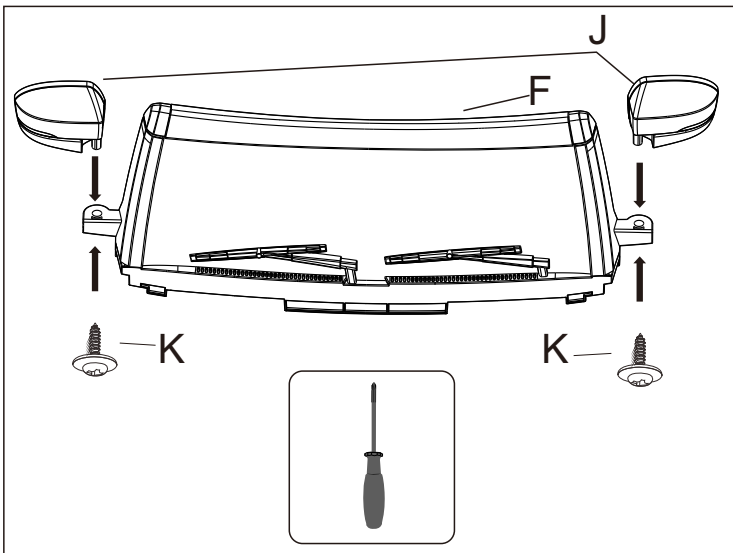

Step 5: Install the rear view window

Fix the J (rear view window) with K (Padded screw) onto the each side of F(wind deflector) as shown in figure.

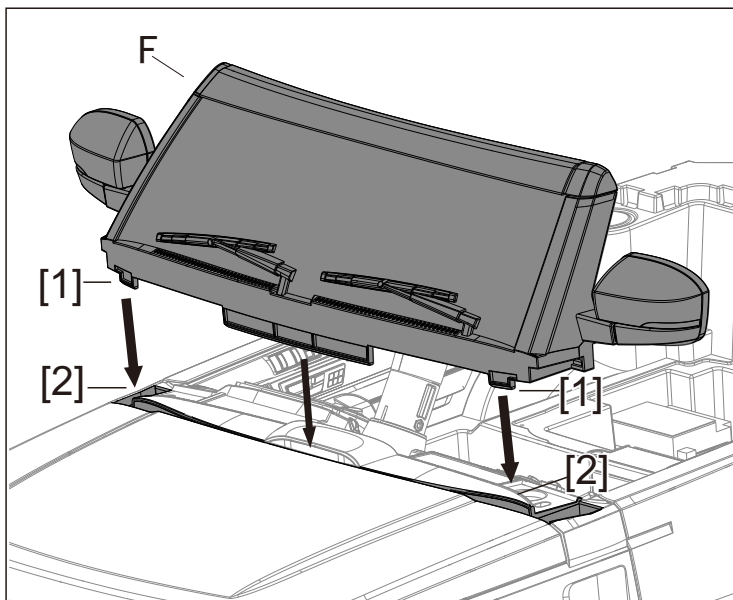

Step 6: Install the wind deflector

Place [1] of F (wind deflector) onto the corresponding [2] groove of car body as shown in figure, press down smoothly.

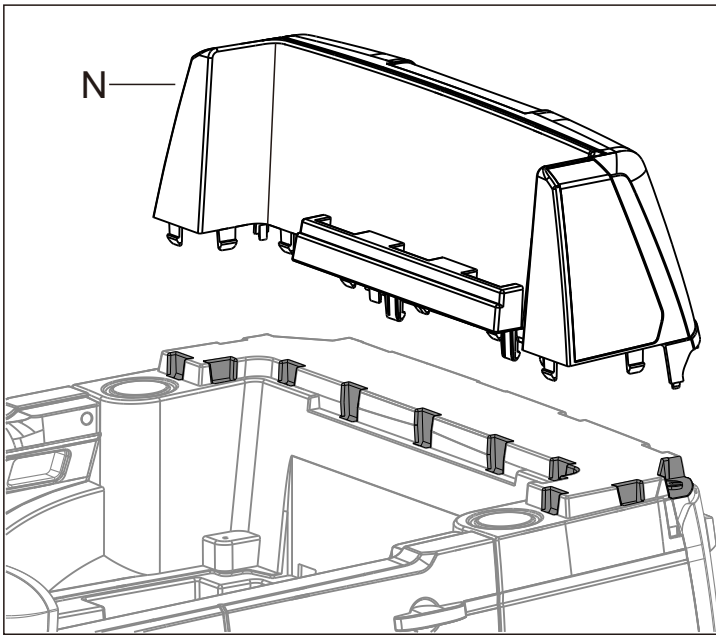

Step 7: Install the rear frame

Align the N (rear frame) buckles as shown in the figure to the car's slot, pressing each one tight.

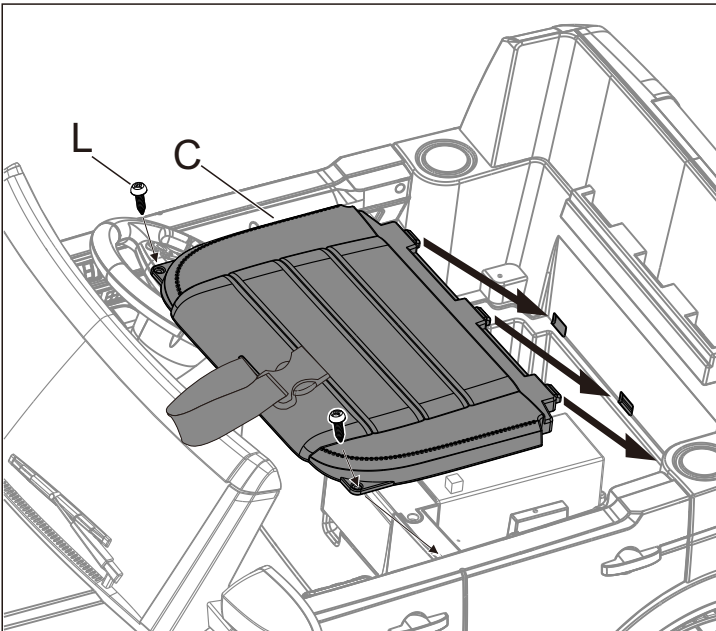

Step 8: Install seat

Install the C (seat) into the designated slots and secure with 2L (self-tapping screws).

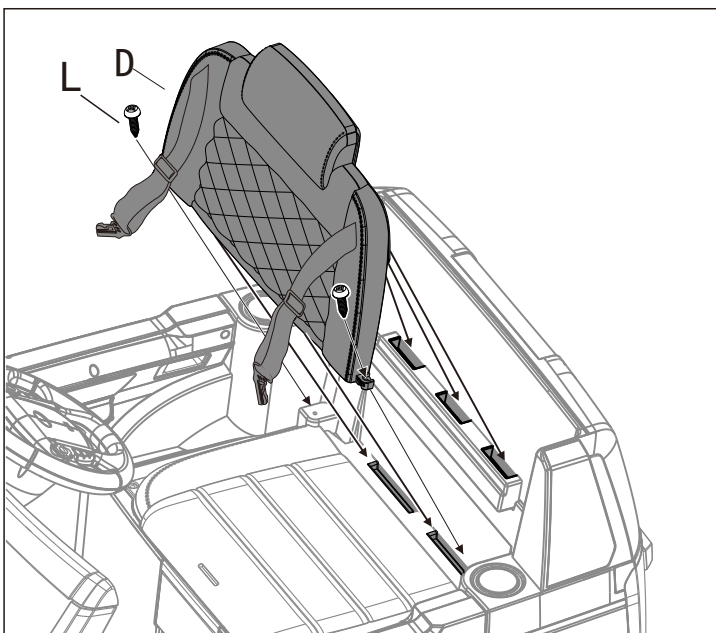

Step 9: Install backrest

Slide the part D (backrest) into the back of the seat until locks in place. Then, secure with 2L (self-tapping screws).

Direction for use

1. The installation and replacement of the batteries in the remote control:

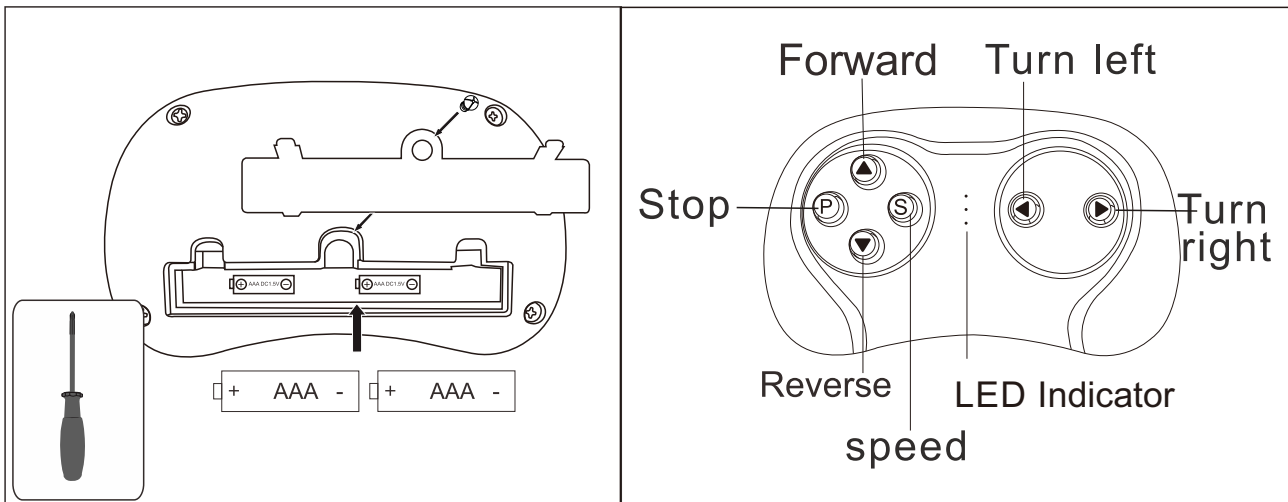

Use a screwdriver to remove the battery cover of the remote control, insert two AAA 1.5V dry batteries in correct polarity. Close the battery cover and fix it with the screw. (Battery replacement also according to the above steps)

2. Matching the frequency of car and remote control

1. Turn off the Power Switch on the car.
2. Remove the battery cover on the Remote Control and put in 2 AAA battery, the three LED indicators will flash.
3. Turn on the Power Switch on the car, when the LED indicators stop flashing and 2 of them are on, matching successes.
4. Once the matching is made, there is no need to match code again only if the battery is replaced.
5. The Remote Control will enter a sleep mode if not used for a long time and the LED indicators will be off. Press any buttons to wake up the Remote Control, and it can be used normally.

Button Description: ▲: forward : ▼ reverse ◀: turn left ▶: turn rights: Speed
P: emergency brake, press it and the running function will fail, press again, it release.

Remote control operating instruction

Remote control is priority (when the car is in Remote control, the remote control personnel can control the car forward and backward, high/Low speed, steering and other functions, the driver CAN NOT operate the car). Press the ▲ forward button, the car goes forward.

Press ▼ reverse button, the car goes reverse.
Press the P button to brake the car urgently. Press P button again to release the brake system. Press the turn left button, car turn left, Press the turn right button, car turn right, The S button is speed button, one light on is low speed, two lights on for intermediate speed, three lights on for high speed.

⚠ WARNING!

- 1.All batteries should be inserted in the correct polarity.
- 2.Non-rechargeable battery cannot be recharged
- 3.Take out and properly deal with the dead battery. To avoid injury, please keep kids away from the battery.
- 4.The direct contact between the positive and negative terminals may result in fire or explosion. Avoid direct connect between the terminals.
- 5.Do not mix old and new batteries. DO not mix alkaline, standard(carbonzinc),or rechargeable(nickel-cadmium) batteries.
- 6.Only an adult who has read and understood the safety warnings can recharge the battery.

3. Instruction of each switch and function button

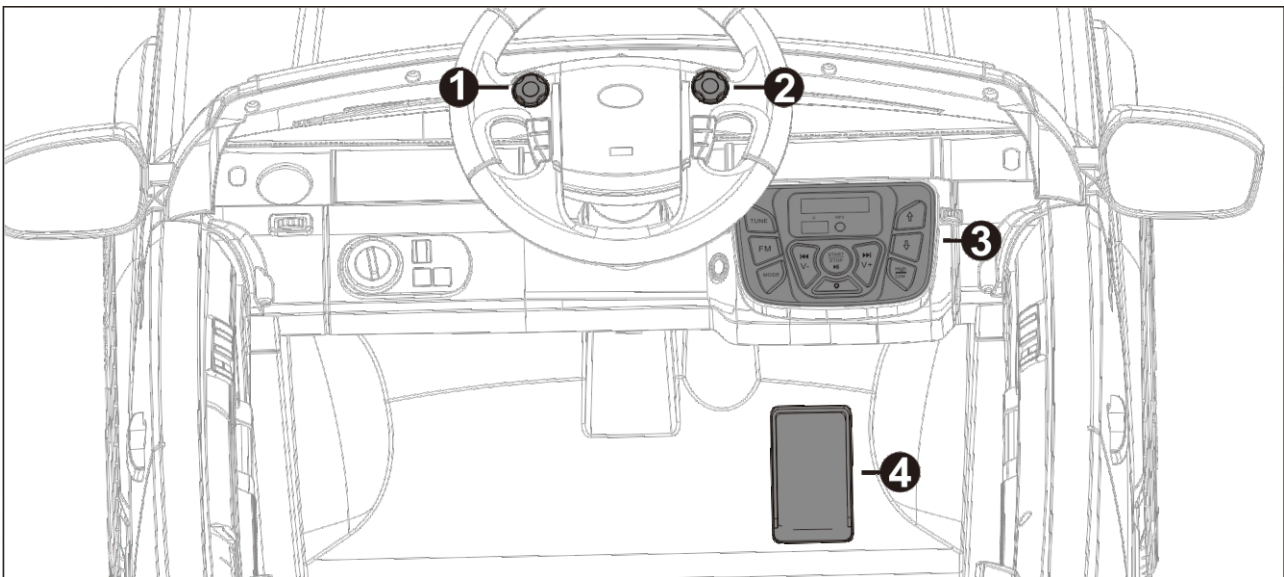

- 1.Engine sound / next song button: when USB and MP3 have no external device input, short press this key will play engine sound ; when USB andMP3 is connected with external device, or under in FM mode, short press this key to play next song. Long press the key to increase the volume.
- 2.Horn button: short press the button to play the horn. long press the horn button can reduce the volume.
- 3.Control board
- 4.Foot pedal switch: step on the foot pedal switch, the car will move forward, loosen the pedal, the car will stop.

4. Instruction of Control board

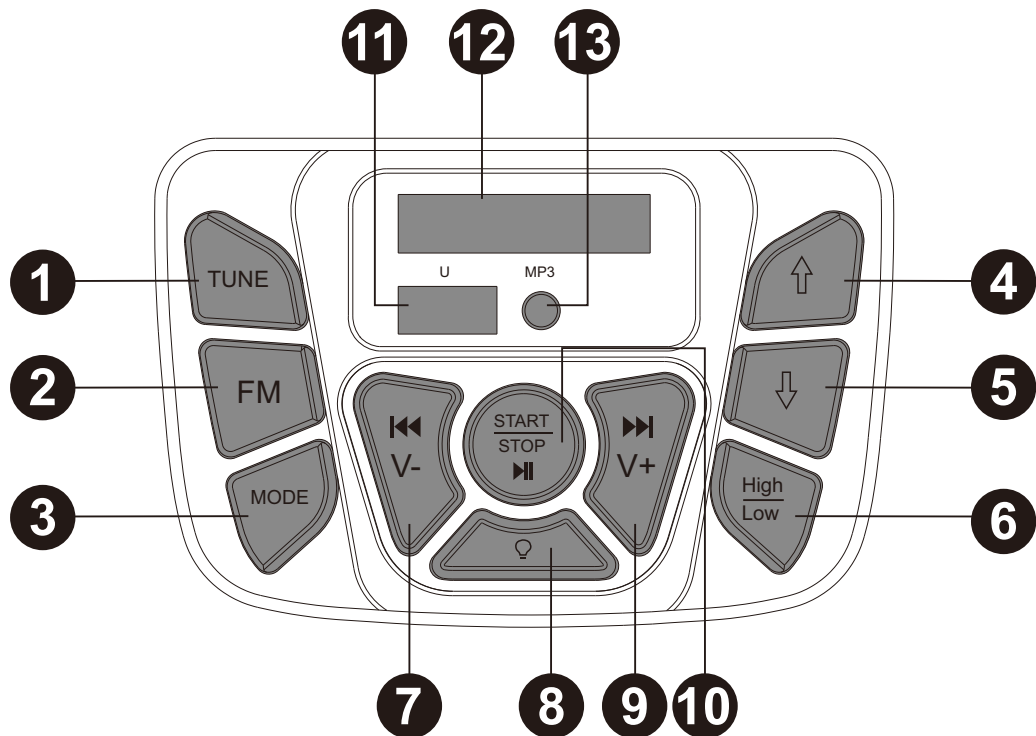

- 1.FM radio search: In FM mode, press this button will search the FM channel.
- 2.FM station: Press this button to enter the FM mode.
- 3.Switch between Music, USB and AUX: Press this button to enter the music mode.
Can switch between different play modes(Music,USB,AUX)
- 4.Forward: Press forward button, step on the foot switch the car will move forward ,loosen the pedal the car will stop.
- 5.Reverse: Press Reverse button, step on the foot switch the car will move Reverse, loosen the pedal the car will stop.
- 6.High/Low speed: Power on, by default, the forward speed is high speed, press the High/low button can change to low speed, press this button again, can change to high speed. For backward, there is only one speed, the high/low button is invalid.
7. ◀◀/V- Previous /VOL down: short press to play the last channel, long press to lower the volume.
8. light switch: Power on, by default, the light is on, press the button to turn off the light.
9. ▶▶/V+Next/ VOL up: Next channel / Volume up: short press to play the next channel, long press to increase the volume.
10. START/STOP/▶▶ : Long press to Turn on or turn off the power; When the music or radio is on, short press can stop it, short press again can restart play it.
11. USB connector: Insert USB will play the music inside. Only MP3 mode is supported.
12. Voltage display screen: The value on the display be used to determine whether the battery needs to be charged.
13. AUX connector: Connect with other removable device to play audio file valid.

5. Operation guide for Manual control (forward, Reverse):

Driver sit down and fasten the seat belt. Long press the Start button, the display will light up, the car will play a start sound(2-5 seconds). Press the forward button and step on the foot switch, the car will move forward, release the foot switch, the car will stop. Press the reverse button and step on the foot switch, the car will move backward, release the foot switch, the car will stop. Long press the Start button again to turn off the power.

6.The illustration of High/Low Speed

Power on, by default, the forward speed is high speed, step on the foot switch, the car will move forward fast, release the foot switch, the car will stop. Press the high/low speed button can change to low speed, step on the foot switch, the car will move forward slowly, release the foot switch, the car will stop. Press the high/low speed button again will change to highspeed.

*** ONLY one speed for reverse, the high/low switch can not control the reverse speed. Everytime when power on, by default, the car will move forward in high speed.**

7.Instructions of the recoverable fuse

Resettable fuse: when the current exceeds a certain rating, the recoverable fuse will automatically cut off the power supply for less than one minute, then the current will be resupplied.

WARNING

RISK OF FIRE. Do not bypass fuse. This may overload and damage the electrical system. Replace only with original size and type.

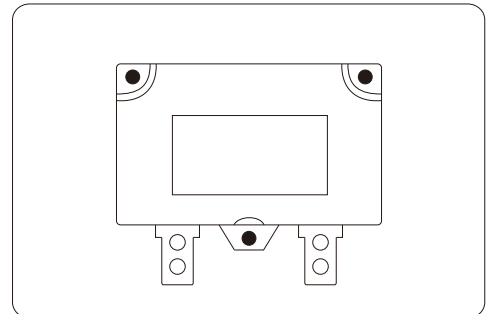

8.Charging instructions.

⚠ WARNING!

Please plug wall charger directly into a wall outlet. Do not use an extension cord.

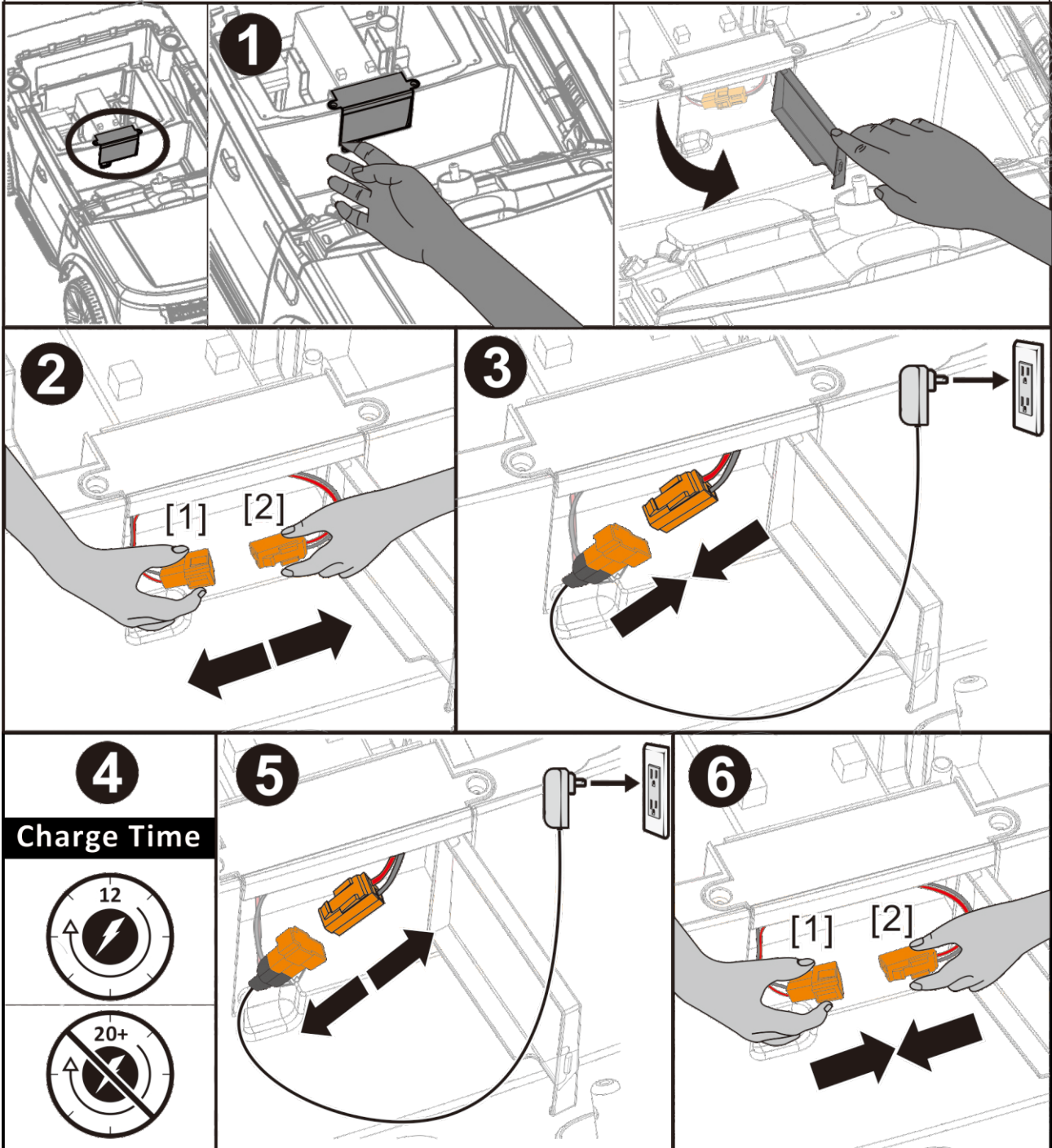

When the battery is low, please charge it immediately.

1. Please find and open the Charging hole cover as shown in figure.2. Press the [2] hook to disconnect the power supply terminal.

3. Connect the charger terminal to the power supply terminal.

4. It can be fully charged within 12 hours (note: Charge it for no more than 20 hours).

5. Firstly please unplug the charger plug out of the socket, then Unplug the charger terminal.

6. Connect the power supply terminal, and close the Charging hole cover.(note: this toy cannot be operated, under charging and should be charged by adults)

Troubleshooting

Fault type	Reason analysis	Trouble elimination methods
The motor does not rotate	<ol style="list-style-type: none"> 1. Is the fuse overloaded? 2. The pedal switch connector is good? 3. The welding of motor electric terminal is good? 4. The connector of the motor wire is good. 5. Remove the motor's plug-in, change to connect battery directly, then check if it rotate or not. 	<ol style="list-style-type: none"> 1. Yes, the fuse cuts off the power automatically by 5-20 seconds, then restart; No, check next reason analysis 2. No, repair foot switch ; Yes, check next reason analysis 3. No, weld the terminal wire ; Yes, check next reason analysis 4. No, plug in the plug-in ; Yes, check next reason analysis 5. Still no rotation, change the motor; If rotates, it means driving circuit board needs professional maintenance, please contact with agent
Only move frontwards, or only move backwards	<ol style="list-style-type: none"> 1. Check the frontward/backward switch, check the connector is good or not by multimeter 2. Check the drive line cycle of frontward/bckwards is workable or not? 	<ol style="list-style-type: none"> 1. No, replace the control board; Yes, check next reason analysis 2. No, connect the line; Yes, it means driving circuit board needs professional maintenance, please contact with agent
slow speed	<ol style="list-style-type: none"> 1. Check the battery voltage is ok or not. 2. Connect the motor (including the driving gearbox) to the battery, then check the speed can be accelerated or not. 	<ol style="list-style-type: none"> 1. No, charger the battery ; Yes it's ok, check next reason analysis 2. No, check next reason analysis ; Yes, it means driving circuit board needs professional maintenance, please contact with agent
The battery can not be recharged	<ol style="list-style-type: none"> 1. The battery connector fall off or loosened. 2. The charger has a slight heat when it is charged 	<ol style="list-style-type: none"> 1. Yes, reconnect it, No, check next reason analysis 2. No, the charger is broken, replace it
When car is moving, the sound and light are useless	<ol style="list-style-type: none"> 1. check the sound/light switch is ok or not. 2. check the electric wire connection (from battery to headstock) is good or not? 	<ol style="list-style-type: none"> 1. No, replace the control board; Yes, check next reason analysis 2. No, reconnect; Yes, check next reason analysis
When wheel running, the car does not move	<ol style="list-style-type: none"> 1. check the driving wheel can be rotated or not? 2. Check the gearbox, if any gear is damaged? 	<ol style="list-style-type: none"> 1. Yes, lay the wheel to the ground; No, checks the next reason analysis 2. Yes, replace the gear box; No, checks the next reason analysis
Car is unstable, moving on and off	<ol style="list-style-type: none"> 1. Does the driver exceed the maximum load weight? 2. Does the driver ride on the rugged road? 3. Check the wheel can rotate freely? 	<ol style="list-style-type: none"> 1. Yes, should follow the instruction, the car unsuitable for exceed maxweight; No, check the next reason analysis 2. Yes, should follow the instruction, ride on the flat cement road ; No, check the next reason analysis No, Troubleshooting wheel and axle

