

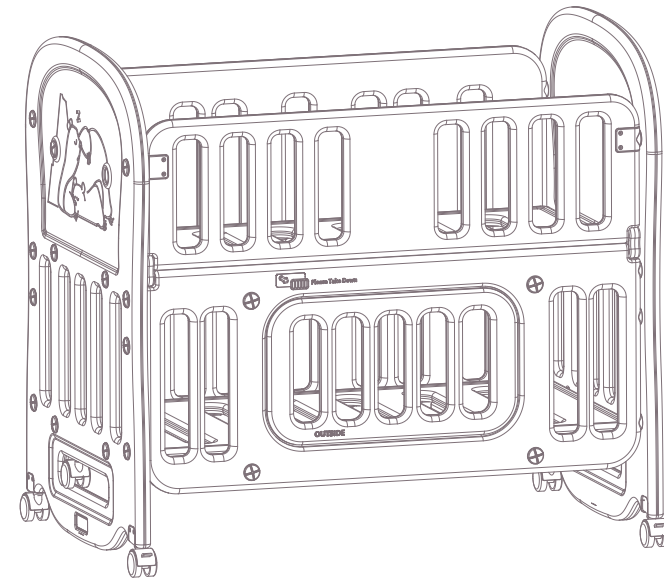

INfh034_US_CA
450-009

0-3Y



EN: Multifunctional Baby Crib Instruction Manual

Imported HDPE Eco-friendly & Non-toxic materials
Increase storage function

FR: Manuel d'Instructions du Lit de Bébé Multifonctionnel

Importation de HDPE écologique et non toxiques
Nouvelle fonction de stockage



READ AND SAVE THIS INSTRUCTION FOR FUTURE USE



US

001-877-644-9366
customerservice@aosom.com



CA

001-855-537-6088
customerservice@aosom.ca



UK

0044-800-240-4004
enquiries@mhstar.co.uk



DE

0049-(0)40-88307530
service@aosom.de



FR

0033-1-84166106
contact@aosom.fr



ES

0034-931294512
atencioncliente@aosom.es



IT

0039-0249471447
clienti@aosom.it

Aosom

Packing Accessories

Unit: mm

Please make sure the accessories are complete. Do not affect installation

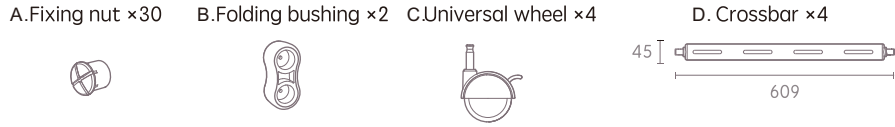

E. Side panel ×2

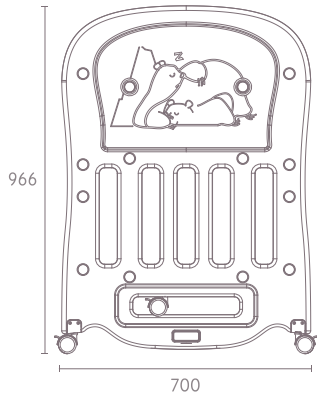

F. Railing panel ×1

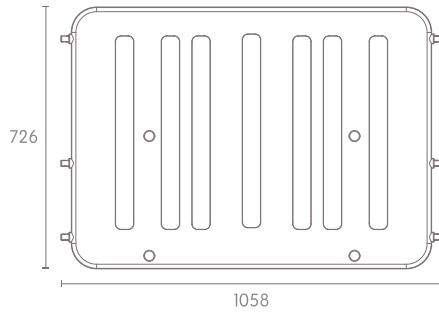

G. Partition panel ×2

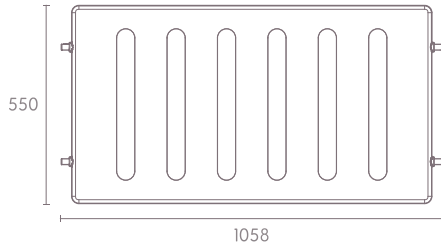

H. Foldable railing panel ×1

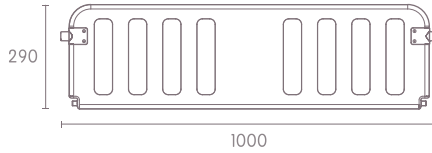

I. Cover of railing under panel ×1 1058

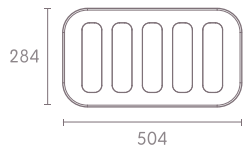

J. Railing Under panel ×1

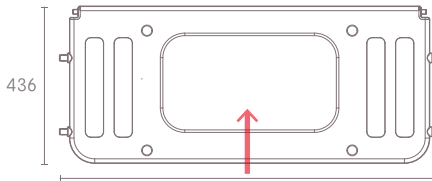

Application

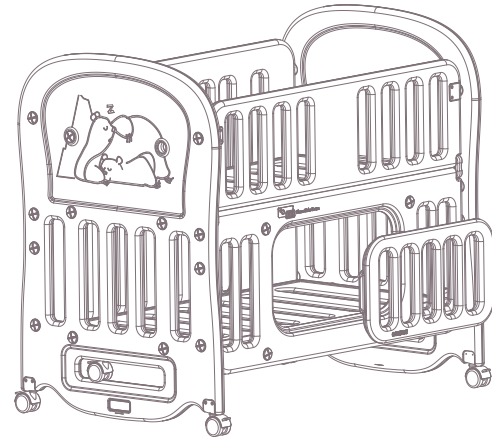

Remove the railing panel cover, there is a large storage space here.

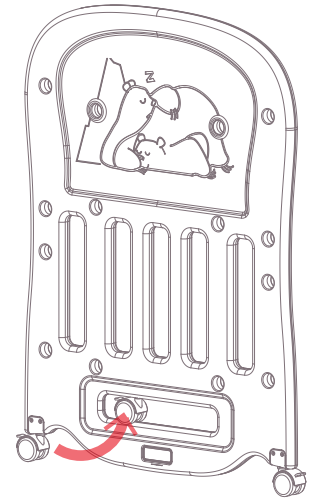

Universal wheel can be stored

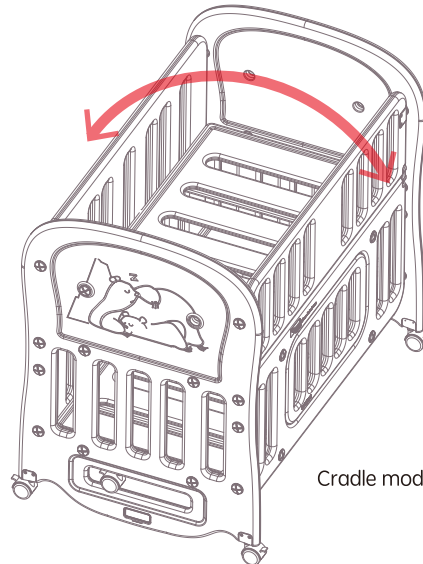

Cradle mode

Installation

1

Place the side panel on flat
Vertical installation the railing panel

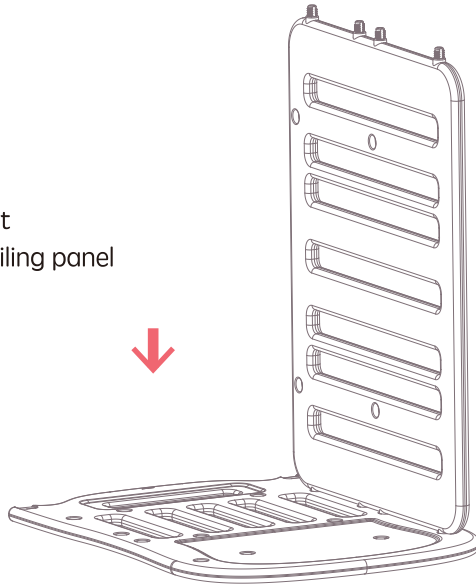

2

Install 4 crossbars

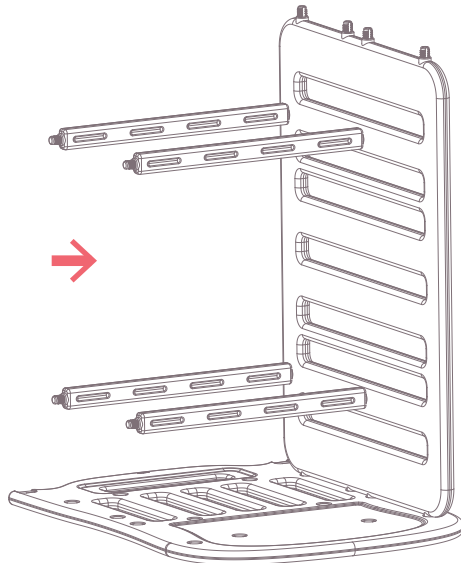

3

3

Installing the partition panel
above the crossbar

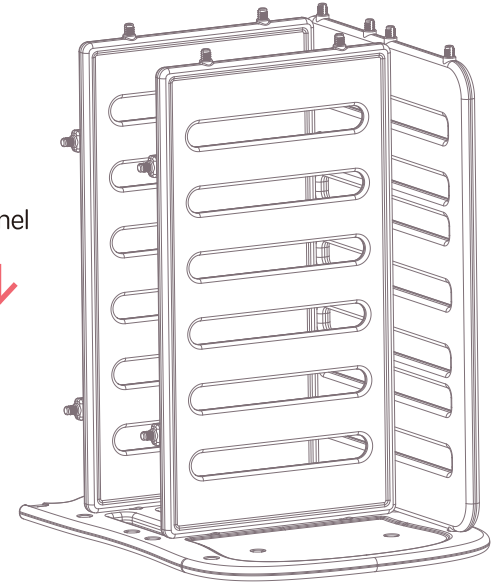

4

- Install the cover to the under railing panel
- The universal wheel (optional)

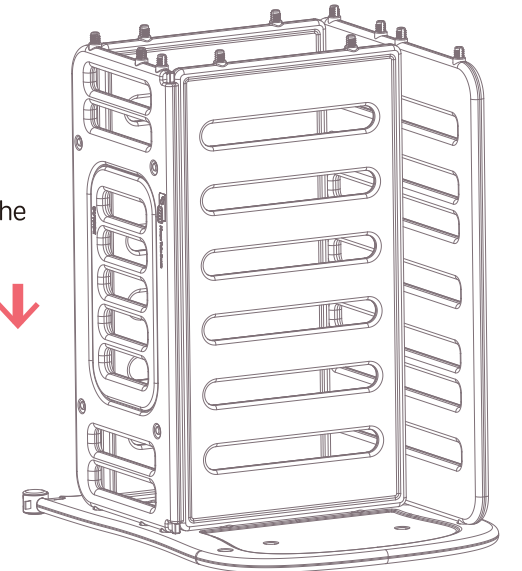

4

Installation

5

Connect the foldable railing panel with the folding bushing

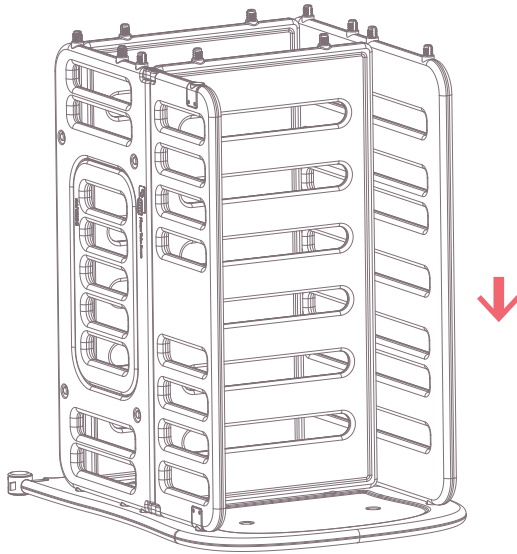

6

- Fasten another partition panel using the fixing nut
- The universal wheel (optional)

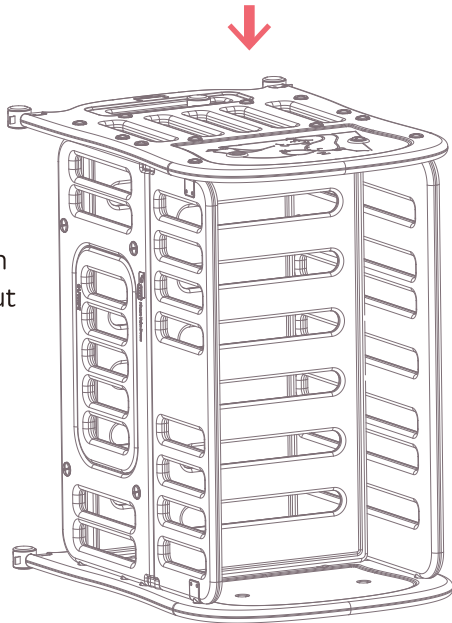

5

7

Flip the crib and tighten all the nuts to complete the installation

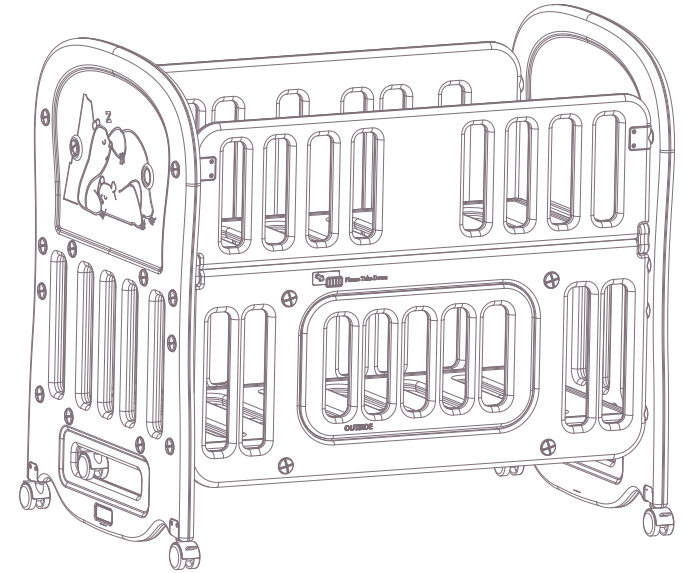

SAFETY INSTRUCTIONS

1. Please check and adjust all parts before use.
2. Check regularly whether the connecting element is stable or not during use.
3. Please clean the crib regularly in case of dirty during use.

6

Tips

1. Suitable age: 0–3 years old, the maximum load is 15 kg.
2. Please use under supervision of adults.
3. Tighten all nuts and confirm that they are installed correctly before use.
4. Keep away from fire and heating installations, deformation possible.
5. Keep your child away from spare parts, screws, etc.
6. Check before use, please do not use if any parts are damaged or broken.

Accessoires d'emballage

Unité: mm

Veuillez vous assurer que les accessoires sont complets.
n'affecte pas l'installation

A. Écrou de fixation *30 B. Douille pliante *2 C. Roue universelle *4 D. Traverse *4



E. Panneau latéral *2

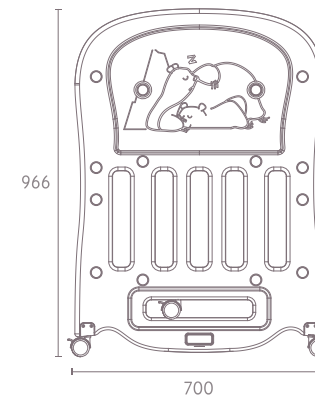

F. Panneau de garde-corps *1

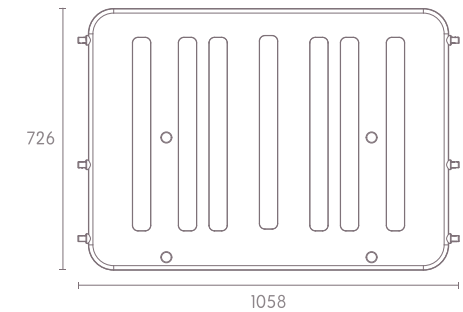

G. Panneau de séparation *2

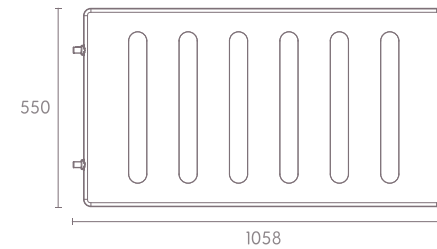

H. Panneau de balustrade *souple *1

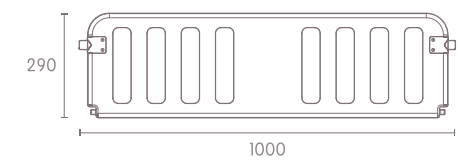

I. Couverture de la balustrade sous le panneau *1

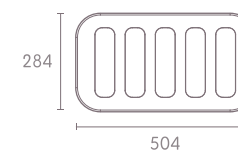

J. Garde-corps sous le panneau *1

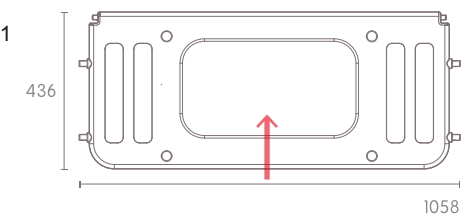

Application

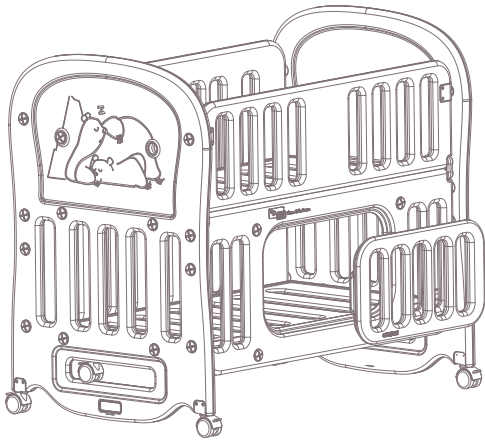

Retirez le couvert du panneau de balustrade, il y a un grand espace de rangement ici.

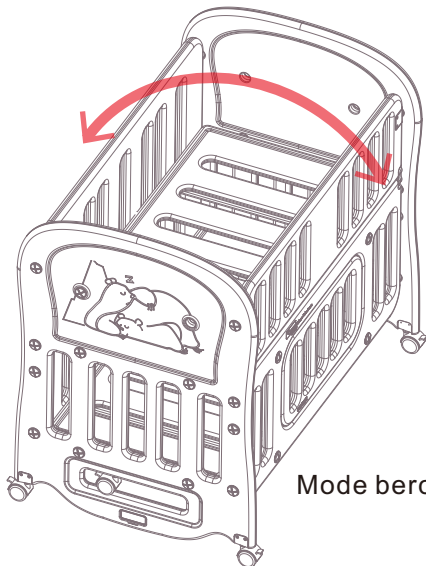

Mode berceau

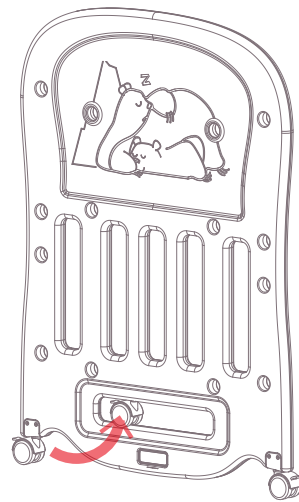

La roue universelle peut être stockée

Installation

1

Placez le panneau latéral sur l'installation verticale plaque du panneau de garde-corps

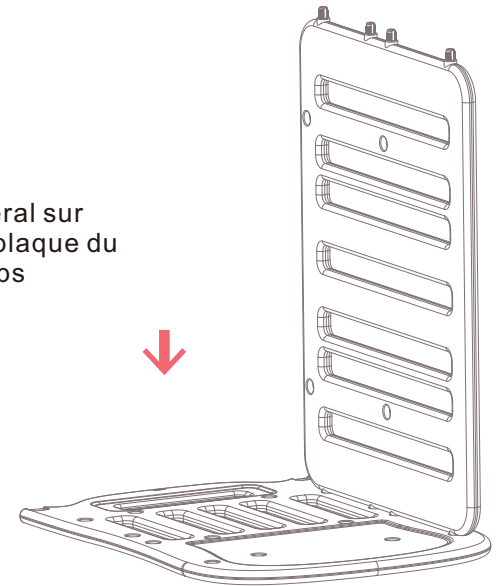

2

Installez 4 barres transversales

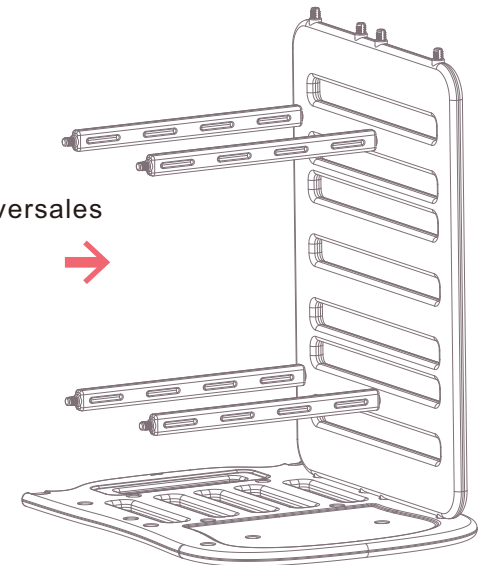

3

Installez le panneau de séparation au-dessus de la barre transversale

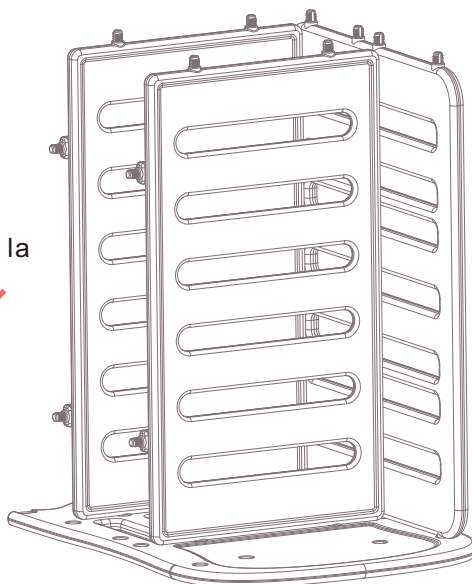

4

Installez le couvercle sous le panneau de garde-corps
Roue universelle (facultative)

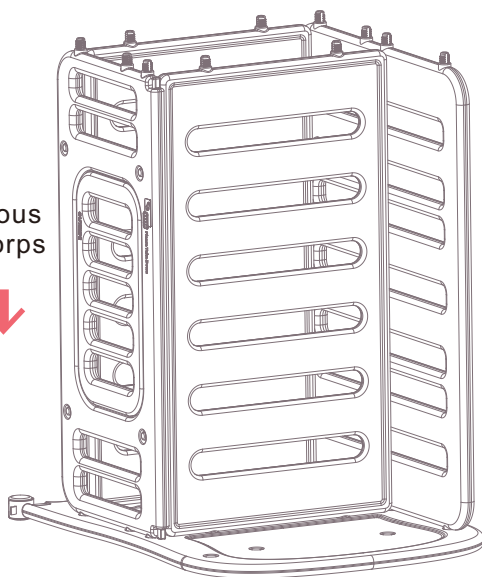

11

Installation

5

Connectez le panneau de garde-corps pliable à la douille pliante

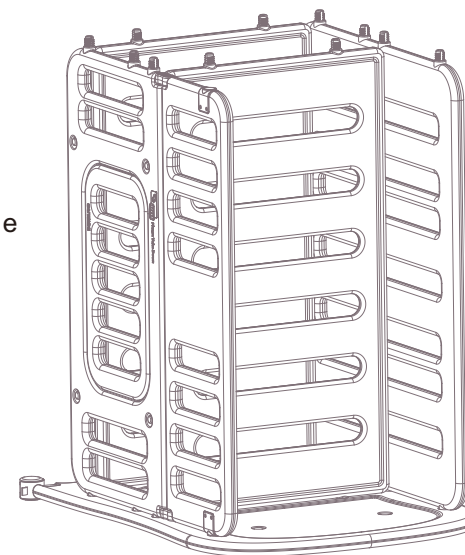

6

Attachez un autre panneau latéral à l'aide de l'écrou de fixation

La roue universelle (facultative)

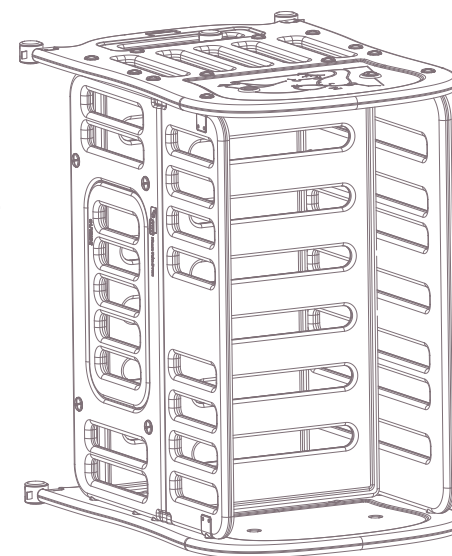

12

7

Retournez le berceau et serrez toutes les écrous pour terminer l'installation.

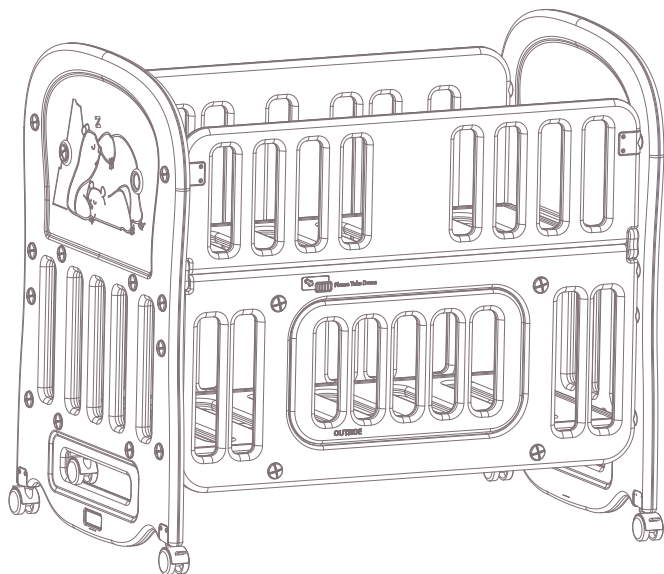

CONSIGNES DE SECURITE

1. Veuillez vérifier et ajuster toutes les pièces avant l'utilisation.
2. Vérifiez régulièrement si l'élément de connexion est stable pendant l'utilisation.
3. Veuillez nettoyer le berceau régulièrement en cas de salissure pendant l'utilisation.

Conseils

1. Age approprié : 0 à 3 ans, la charge maximale est de 15 kg.
2. Veuillez utiliser sous la supervision d'un adulte.
3. Serrez toutes les noix et confirmez qu'elles sont installées correctement avant utilisation.
4. Tenez à l'écart du feu et des installations de chauffage, il risque de provoquer la déformation possible.
5. Tenez votre enfant éloigné des pièces de rechange, des vis, etc.
6. Vérifiez avant l'utilisation, veuillez ne pas utiliser si des pièces sont endommagées ou cassées.