

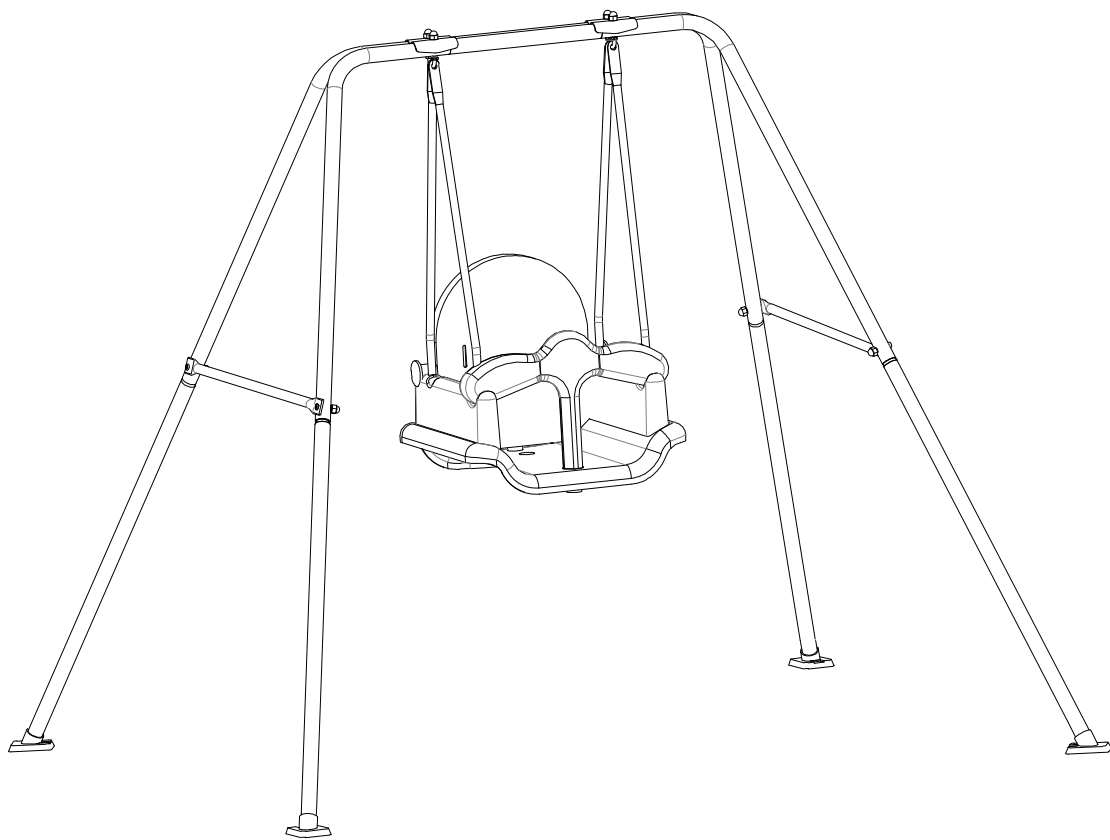

INfka005V03_GL

344-025



EN_IMPORTANT, RETAIN FOR FUTURE REFERENCE: READ CAREFULLY.

FR_IMPORTANT: A LIRE ATTENTIVEMENT ET À CONSERVER POUR CONSULTATION ULTÉRIURE.

ES_IMPORTANTE, LEA Y GUARDE PARA FUTURAS REFERENCIAS.

DE_WICHTIG! SORGFÄLTIG LESEN UND FÜR SPÄTER NACHSCHLAGEN AUFBEWAHREN.

IT_IMPORTANTE! CONSERVARE IL PRESENTE MANUALE PER FUTURO RIFERIMENTO E LEGGERLO ATTENTAMENTE.

**EN:WARNING:**

Check all the parts are well connected before use.

Regularly check and maintain the main components (suspenders, fasteners, fixings, etc.), otherwise the swing may tip over or cause a fall.

Never leave your child unattended. Use under adult supervision.

Do not stand on the swing, always keep your hands on the swing string.

Age for 6-36 months.

Maximum loading weight: 30kgs/seat

DE:WARNUNG:

Überprüfen Sie vor dem Gebrauch, ob alle Teile richtig angeschlossen sind.

Überprüfen und warten Sie regelmäßig die Hauptkomponenten (Hosenträger, Befestigungselemente, Befestigungen usw.), da sonst die Schaukel umkippen oder einen Sturz verursachen kann.

Lassen Sie Ihr Kind niemals unbeaufsichtigt. Verwendung unter Aufsicht von Erwachsenen.

Stellen Sie sich nicht auf die Schaukel, sondern halten Sie Ihre Hände immer an der Schaukel.

Alter für 6-36 Monate.

Maximales Ladegewicht: 30 kg/Sitz

FR:ATTENTION:

Vérifiez que toutes les pièces sont bien connectées avant utilisation.

Vérifiez et entretenez régulièrement les principaux composants (bretelles, attaches, fixations, etc.), sinon la balançoire pourrait basculer ou provoquer une chute.

Ne laissez jamais votre enfant sans surveillance. Utiliser sous la surveillance d'un adulte.

Ne vous tenez pas debout sur la balançoire, gardez toujours vos mains sur la corde de la balançoire.

Âge de 6-36 mois .

Poids de chargement maximum: 30kgs/siège

IT:ATTENZIONE:

Verificare che tutte le parti siano ben collegate prima dell'uso.

Controllare e mantenere regolarmente i componenti principali (bretelle, elementi di fissaggio, fissaggi, ecc.), Altrimenti l'oscillazione potrebbe ribaltarsi o causare una caduta.

Non lasciare mai tuo figlio incustodito. Utilizzare sotto la supervisione di un adulto.

Non stare in piedi sull'altalena, tieni sempre le mani sulla corda dello swing.

Età per 6-36 mesi.

Peso massimo di carico: 30 kg/posto

ES:ADVERTENCIAS:

Compruebe que todas las piezas estén bien conectadas antes de su uso.











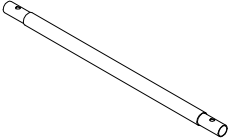

Revise y mantenga regularmente los componentes principales (tirantes, sujetadores, fijaciones, etc.), de lo contrario, el columpio puede volcarse o provocar una caída.

Nunca deje a su hijo sin supervisión. Usar bajo la supervisión de un adulto.

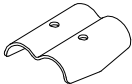
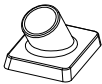
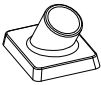
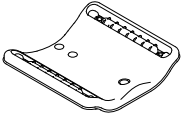
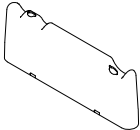
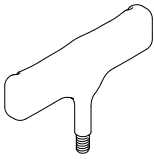
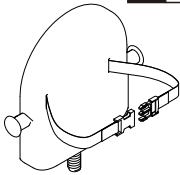
No se pare en el columpio, mantenga siempre las manos en la cuerda del columpio.

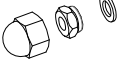
Edad de 6 a 36 meses.

Peso máximo de carga: 30kgs/asiento

 ① x 2	 ② x 2	 ③ x 2	 ④ x 4	
 ⑤ x 2	 ⑦ x 4	 ⑧ x 2	 ⑨ x 2	 ⑩ x 2
 ⑪ x 2	 ⑫ x 1	 ⑬ x 2	 ⑭ x 1	 ⑮ x 1
 ⑯ x 2	 ⑰ x 8	 ⑱ x 4	 $\phi 4$ ⑲ x 1	 $\phi 10$ ⑳ x 1

M6*35

01

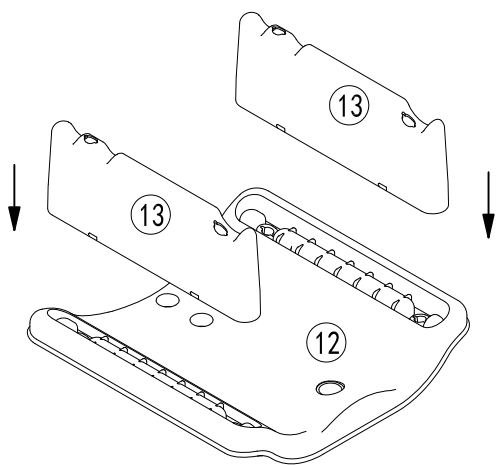

02

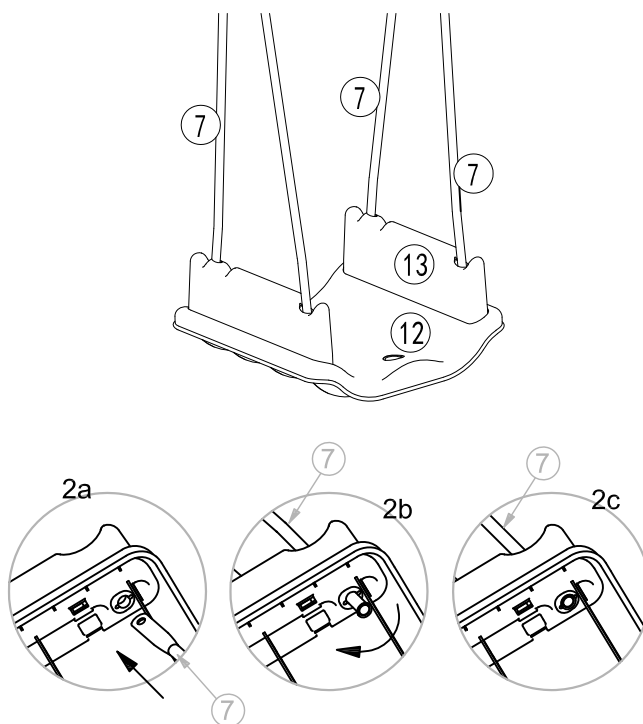

03

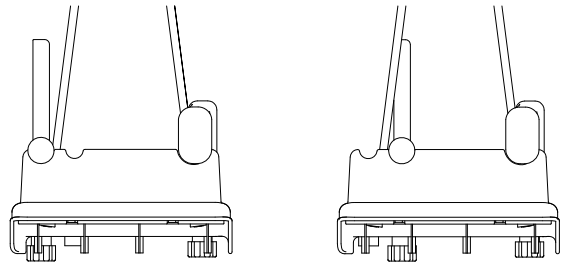
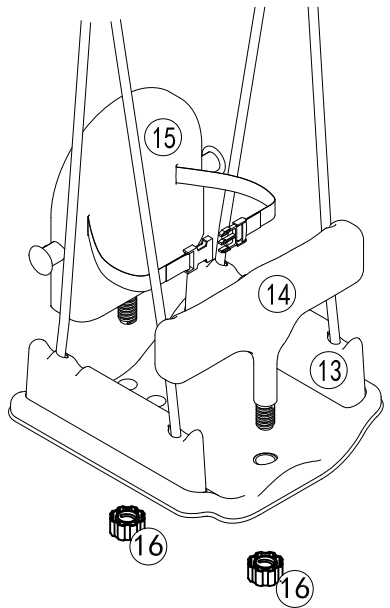

04

8	x2
17	x4

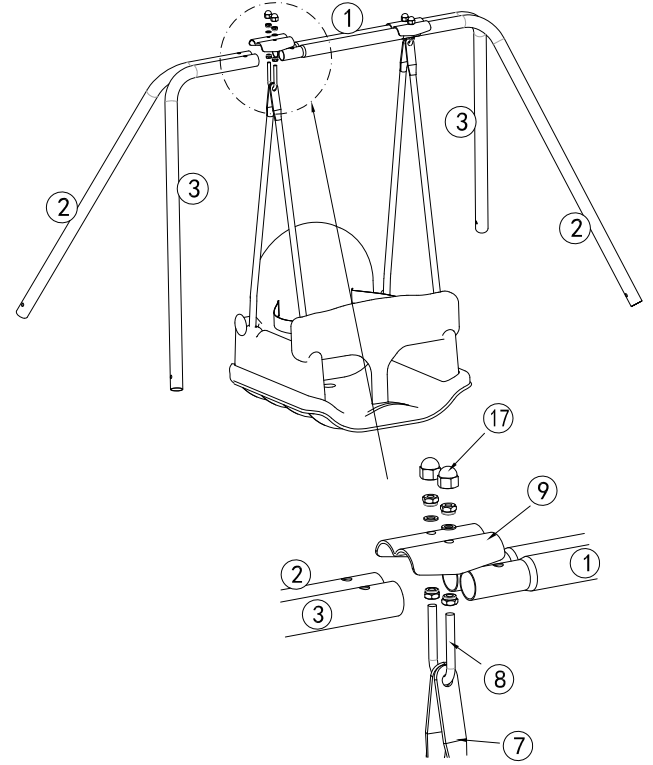

05

17	x4
18	x4

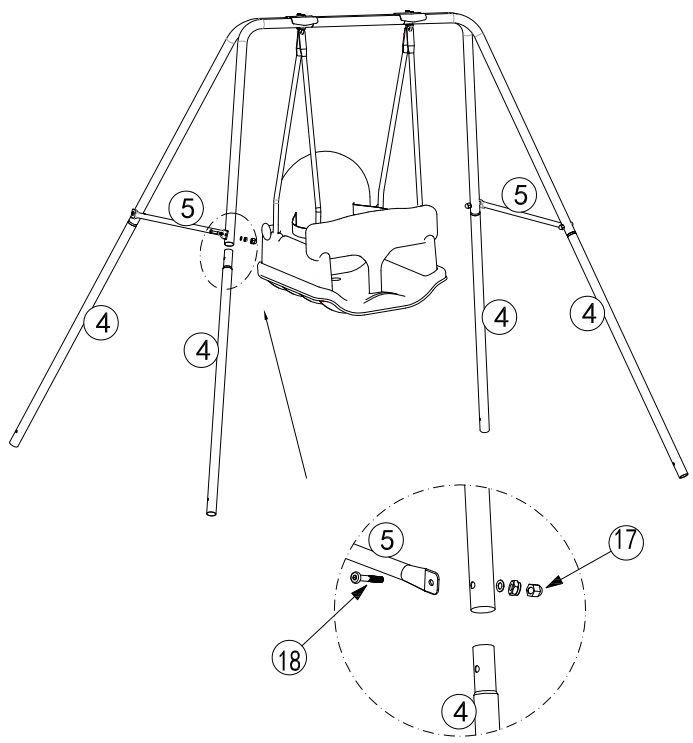

06

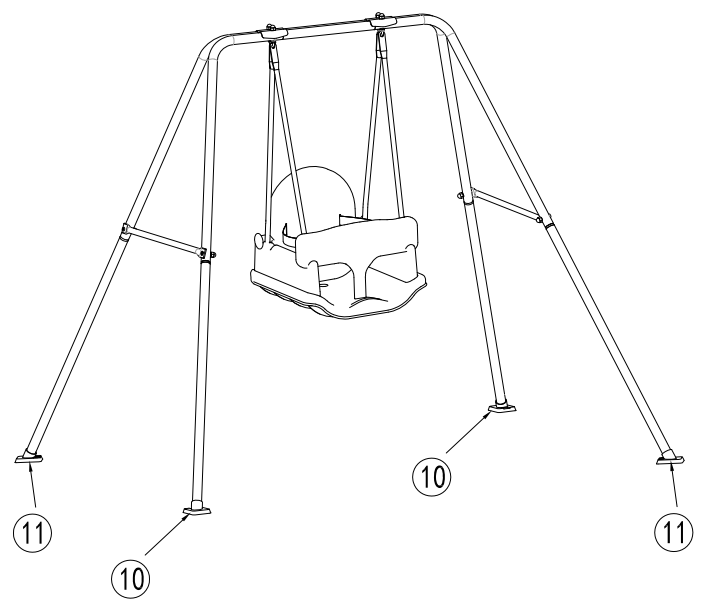

IMPORTER

Imported by Aosom LLC
27150 SW Kinsman Rd Wilsonville, OR 97070 USA
Manufactured in Ningbo City, Zhejiang Province, China
MADE IN CHINA

IMPORTER

Imported by Aosom Canada Inc.
1251 Tapscott Road, Unit 101, Scarborough, Ontario Canada M1X 1S9
Manufactured in Ningbo City, Zhejiang Province, China
MADE IN CHINA

IMPORTER

MH STAR UK LTD
Address: Unit 27, Perivale Park, Horsenden lane South
Perivale, UB6 7RH
MADE IN CHINA

IMPORTATEUR

MH Handel GmbH
Wendenstraße 309
D-20537 Hamburg
Germany
IN CHINA HERGESTELLT

IMPORTEUR

MH FRANCE
2 Rue Maurice Hartmann
92130 Issy Les Moulineaux
France
FABRIQUÉ EN CHINE

IMPORTATO DA

AOSOM Italy srl
Centro Direzionale Milanofiori
Strada 1 Palazzo F1
20057 Assago (MI)

P.I.: 08567220960
FATTO IN CINA

IMPORTADOR POR

SPANISH AOSOM, S.L.
C/ ROC GROS, Nº 15. 08550, ELS
HOSTALETS DE BALENYÀ, SPAIN.
B66295775

WWW.AOSOM.ES
ATENCIONCLIENTE@AOSOM.ES
TEL: 931294512
HECHO EN CHINA

